

INSTALLATION GUIDE
PERMOBIL M3 / M5



INSTALLATION GUIDE PERMOBIL M3 / M5

PACKAGE CONTENTS

- A. LUCI SmartFrame™ (1)
- B. Scout (1)
- C. Footplate Template (2)
- D. LUCI RNET Adapter Cable Kit (1)
- E. Dashboard (1)
- F. Dashboard Reference Card (2)
- G. Standard (Joystick) Dashboard Bracket (1)
- H. Alternative Drive Dashboard Bracket (1)
- I. LuciLink™ Hub & Wheelchair Key™ (1)
- J. 3/16 Inch Drill Bit (1)
- K. Thumbscrew (2)
- L. M8 Hex Bolt (2)
- M. M4 x 16mm Screw (3)
- N. M5 x 8mm Hex Head Screw (2)
- O. 4-40 x 3/16 Inch Screw (4)
- P. Alcohol Wipe (1)
- Q. Zip Ties
- R. (Optional) Headlight Kit & Instructions (1)

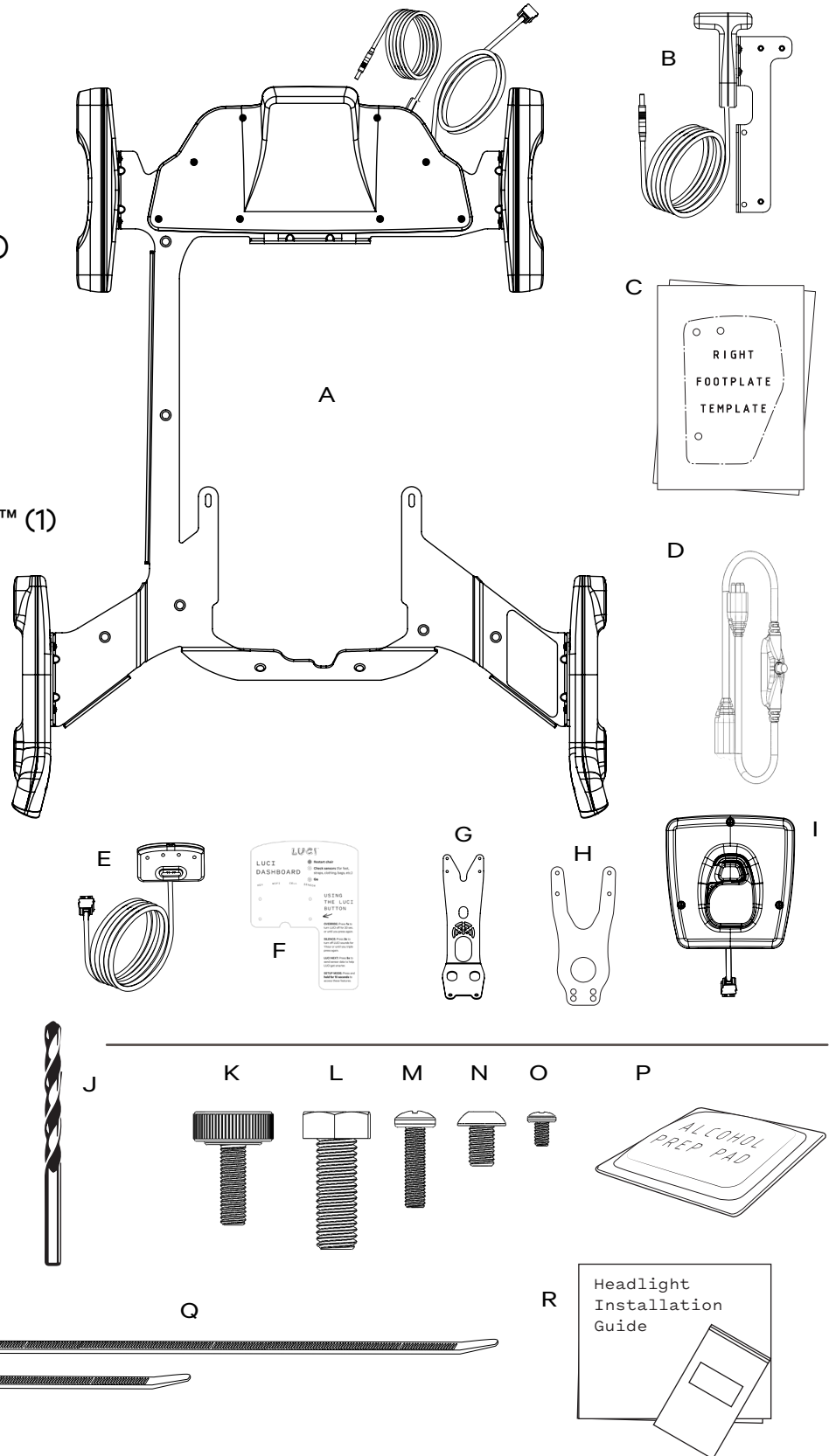

NOTE: You will also need:

- 2.5mm Allen Wrench
- 3mm Allen Wrench
- 6mm Allen Wrench
- 13mm Wrench
- Phillips P1 Screwdriver
- Power Drill
- Adhesive Tape
- Brush & Dustpan or Vacuum
- Zip Tie Snips
- Flathead Screwdriver

INSTRUCTIONS

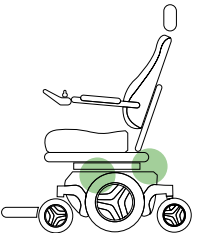

STEP 1 - PREPARE WHEELCHAIR BASE

Tools Required

- 6mm Allen Wrench
- M8 Hex Bolts (L)

Using a 6mm Allen wrench, remove one of the two bolts on the back of the wheelchair (Figure 1A) and set it aside. In its place, insert an M8 hex bolt (L) and hand tighten, leaving about ¼ inch spacing (Figure 1B). Repeat with the other bolt. Do not overtighten!

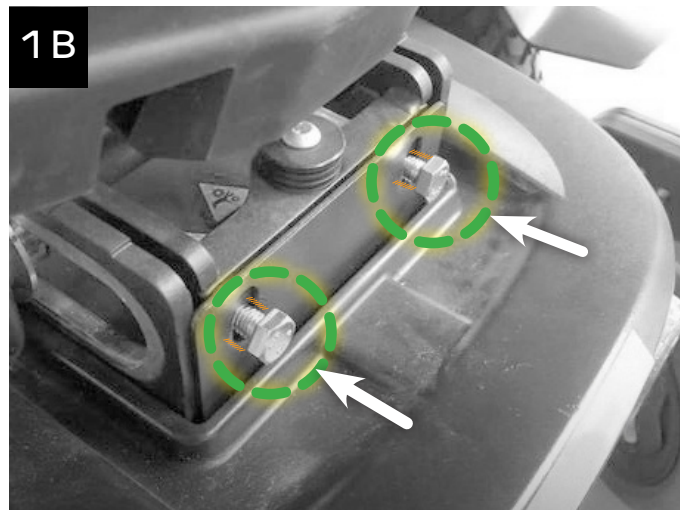
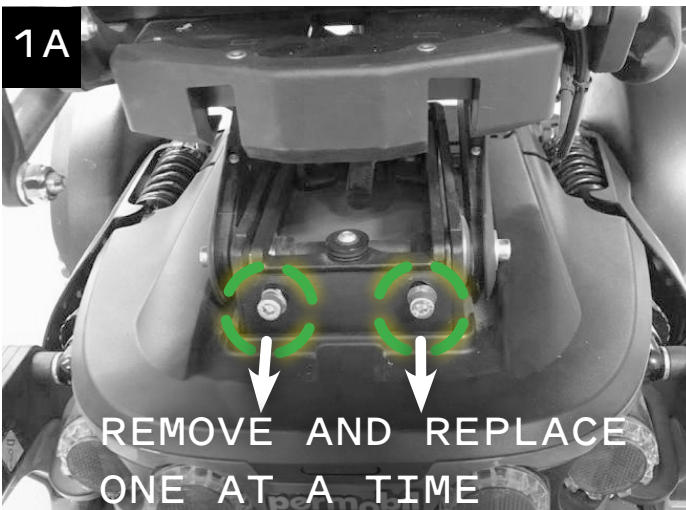

Power the wheelchair on and raise the chair seat and legs to gain appropriate access (Figure 1C). For models with a raising seat, raise the seat out of the way. Power the wheelchair off and turn off the main breaker on the back of the chair. Remove the two thumbscrews underneath the seat on the wheelchair base and set them aside (Figure 1D).

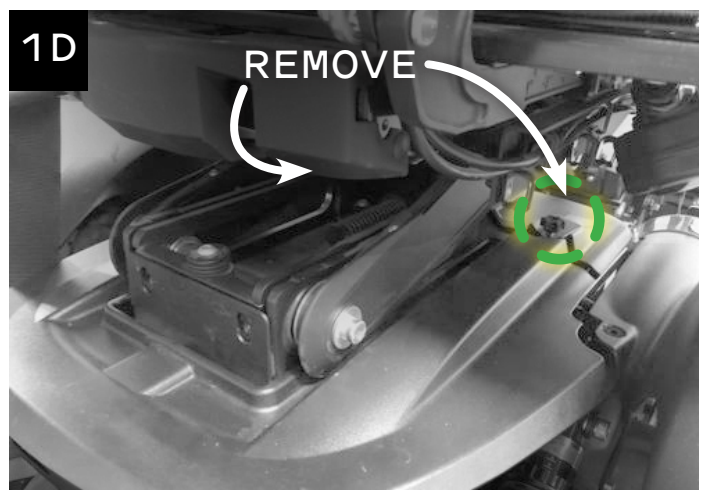

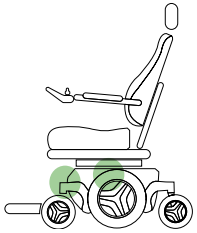

STEP 2 - PLACE THE LUCI SMARTFRAME

Tools Required

- (Optional) Headlight Kit and Instructions (R)
- LUCI SmartFrame (A)

i If the wheelchair has headlights, use the Headlight Kit (R) and follow the included instructions to remove them now.

Hook the LUCI SmartFrame (A) around the seat mechanism beginning at the front and rotating 90° clockwise (Figure 2A). Slot the LUCI SmartFrame down onto the bolts on the back of the wheelchair. Ensure that the LUCI SmartFrame is lying flat on the wheelchair base and is not pinching any existing cables or hardware (Figures 2B and 2C).

If the wheelchair has headlights, finish the final step of the Headlight Kit (R) instructions to insert the brackets between the SmartFrame and front FusionSensor pods.

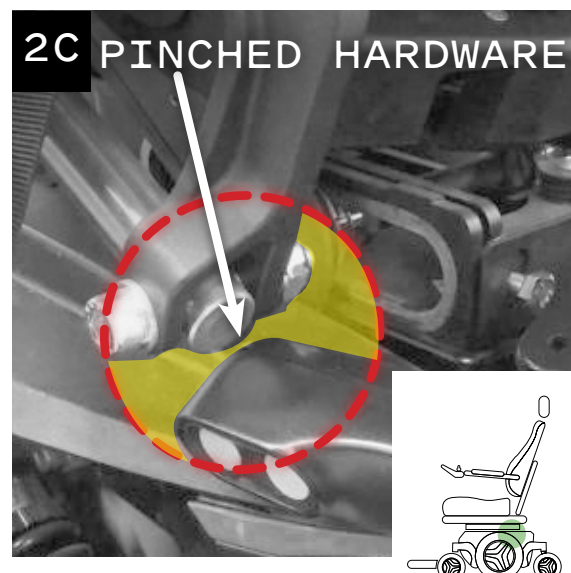
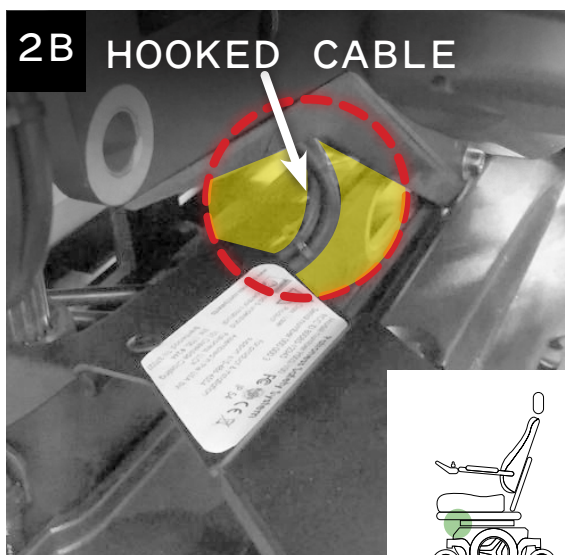
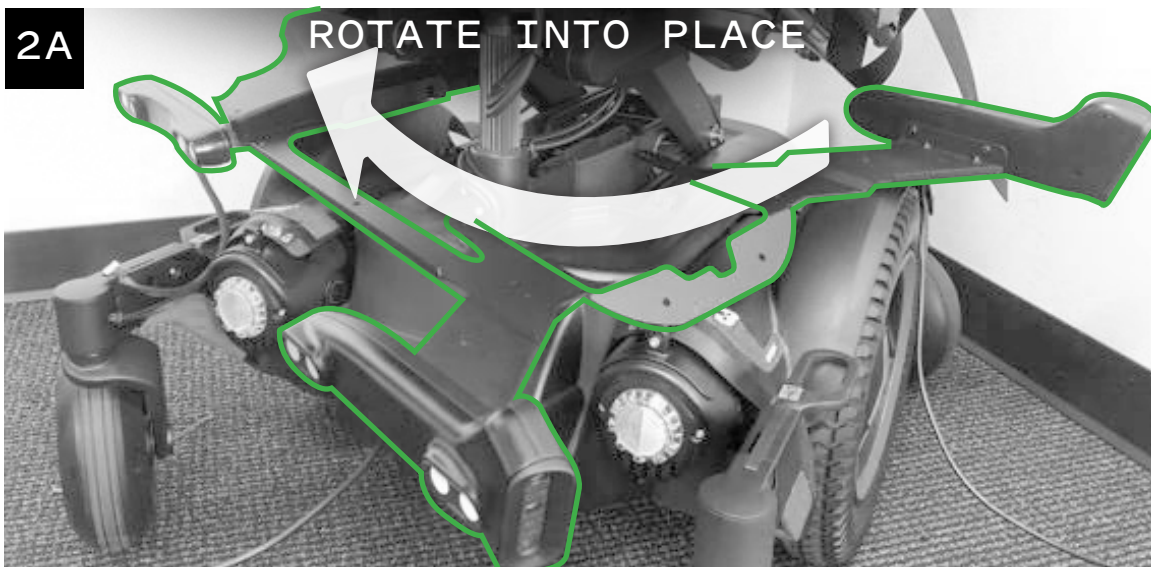

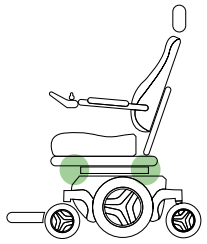

STEP 3 - SECURE THE SMARTFRAME

Tools Required

- 13mm Wrench
- Thumbscrews (K)

Insert and tighten the two thumbscrews (K) on the front of the chair (Figure 3A). Tighten the two M8 hex bolts (L) on the back of the chair with a 13mm wrench (Figure 3B).

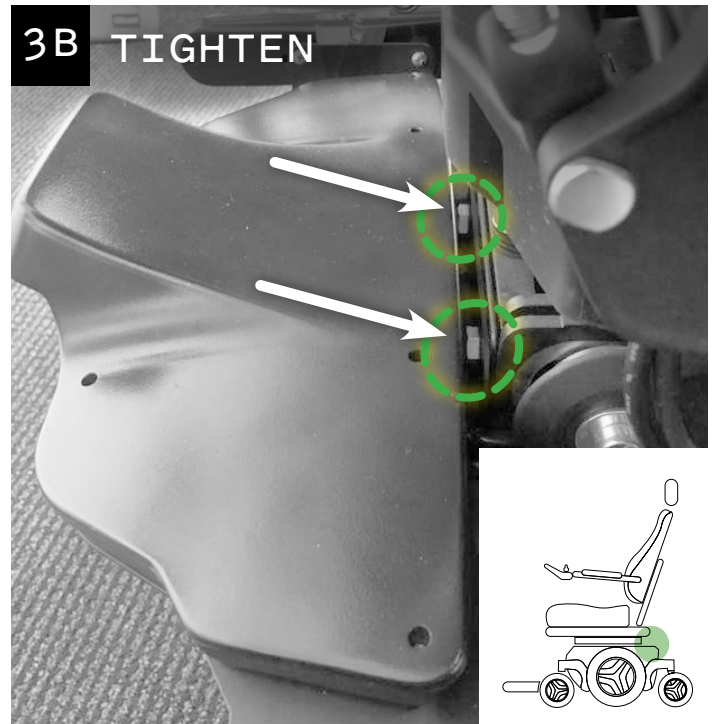
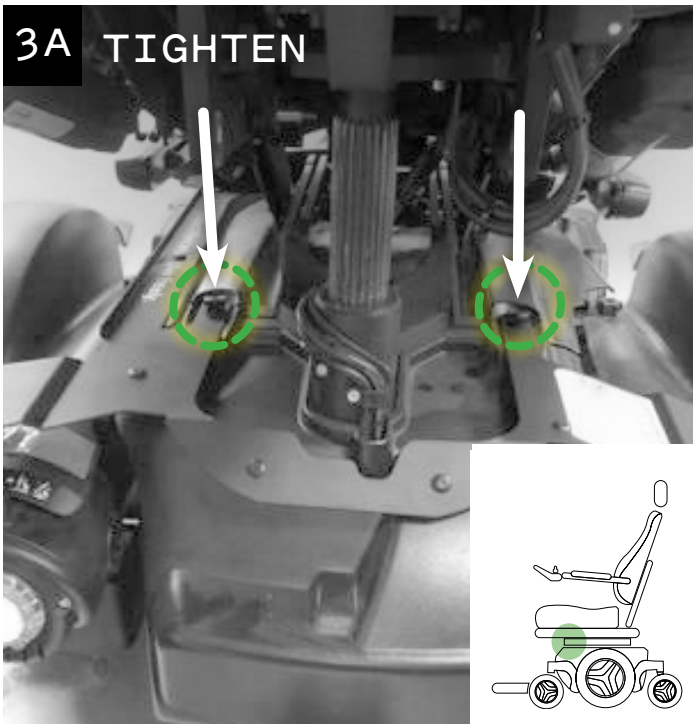

i Note: If necessary, the SmartFrame can be bent slightly to better align the thumbscrew holes.

⚠ Caution: Ensure that the two cables exiting the SmartFrame are routed on top of the LUCI unit.

⚠ Caution: Ensure that the front camera FusionSensors on the front of the unit are level.



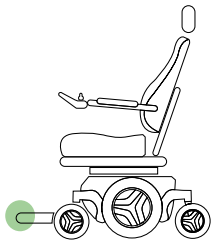

STEP 4 - ATTACH SCOUT

Tools Required

- Footplate Template (C)
- 3/16 Inch Drill Bit (J)
- M4 x 16mm Screws (M)
- Scout (B)
- Zip Ties (Q)
- Adhesive Tape
- Drill
- Brush and Dustpan OR Vacuum
- Phillips Screwdriver

Lower the foot rest completely. Align the correct Footplate (standard or wide) Template (C) on the right footplate (Figure 4A) and tape it in place so that it does not shift. Use a Phillips screwdriver to make pilot hole marks in the footplate template to help with drilling the holes in the correct location. Insert the drill bit (J) into your drill and drill the three holes. Ensure the holes on the footplate bracket line up with the holes you drilled.



i Note: For extra wide footplates, use the wide footplate template, aligning it in the inside, forward corner of the footplate.

⚠ Caution: Use a brush or vacuum to get rid of the metal shavings as these are sharp!

Use three M4x16mm screws (M) to screw the Scout (B) to the underside of the footplate (Figure 4B).

Route the Scout cable along the side and top of the footplate as shown (Figure 4C), then along the back of the leg rest, using zip ties (Q) to secure it to the stationary bracket low on the leg rest (Figure 4D).

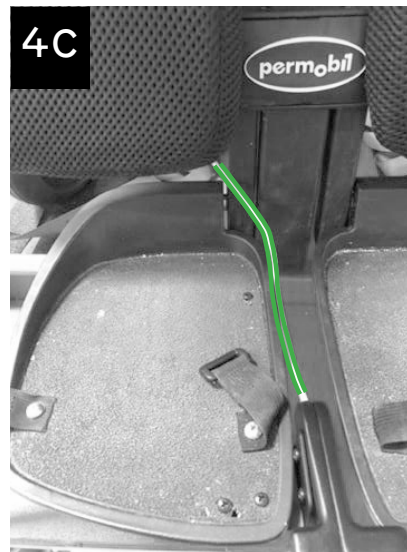
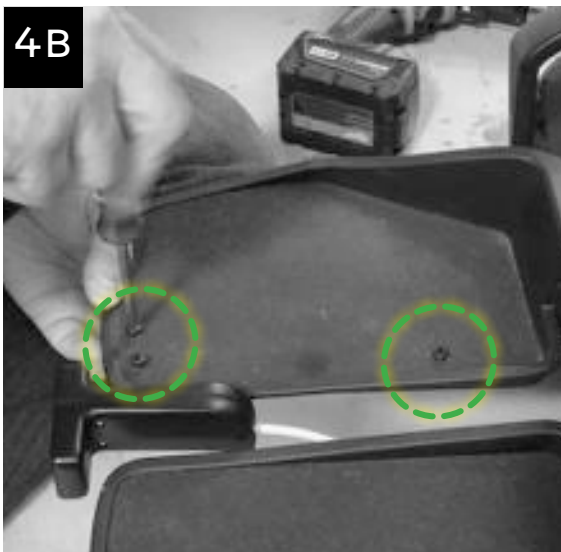

Raise the foot rest to its fullest extent (Figure 4E) and use a long zip tie (Q) to secure the cable to the stationary bracket just under the seat (Figure 4F).

From there, route the Scout cable toward the back of the chair, following existing cabling underneath the seat and utilizing the existing cable clips (Figure 4G).

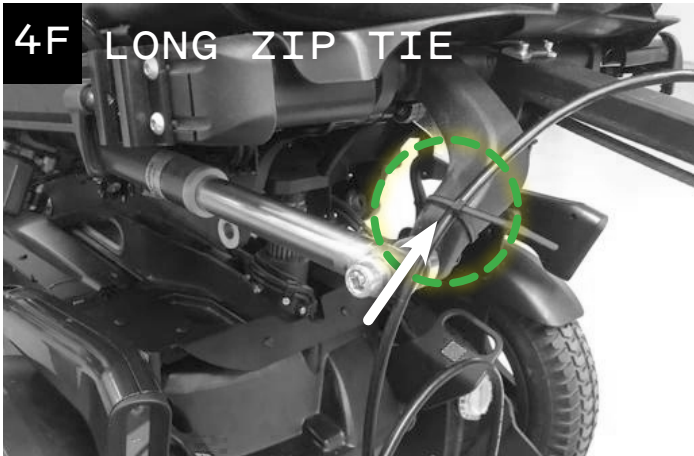

⚠ Caution: Do not route the cable below the footplate, as this may cause damage to the cable.

⚠ Caution: Ensure there is enough slack in the USB cable so that the seat and foot rest can move to their full extent, without dragging the cable.

⚠ Caution: Ensure that the full extent of the cable is secured with zip ties and cable clips where possible. If necessary, foot straps may be screwed in through the footplate bracket after installation.

⚠ Caution: All cables should be installed, bundled and routed so as to avoid damage to the cables through pinching, dragging, etc. and to avoid excess cable length that could lead to entanglement or strangulation.

i Note: If the driver typically drives with the footplate raised, the Scout should be adjusted to an orientation that is level with the ground, to ensure proper functioning and obstacle detection. Refer to Step 4B for adjustment information.

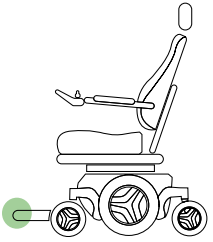

STEP 4B - ADJUSTABLE SCOUT OPTIONS (OPTIONAL)

Tools Required

- Phillips P1 Screwdriver

The Scout works best when it is mounted level with the ground, or facing slightly upward. For drivers who drive with their footplate in the standard position, the default position of the Scout will work well and this step can be skipped (Figure 4H). However, if the driver typically drives with the footplate raised or lowered, the Scout should be adjusted to an orientation that is level with the ground, to ensure proper functioning and obstacle detection.

The adjustable footplate bracket allows for significant variability in Scout orientation (Figure 4I). If the driver typically drives with the footplate up, the Scout can be mounted at up to -50 degrees (Figure 4J). If the driver typically drives with the footplate lowered, the Scout can be mounted at up to 15 degrees (Figure 4K). If the driver has a one piece footplate, the Scout bracket can also be mounted upside-down near the center of the footplate. Note that the Scout itself should still be mounted in the standard orientation (Figure 4L).

⚠ Caution: Do not mount the Scout facing downward, as this will cause it to see the ground as an obstacle and inhibit forward motion (Figure 4M).

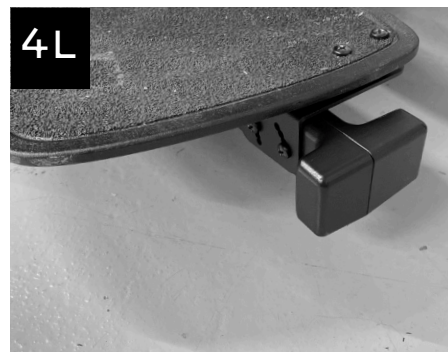
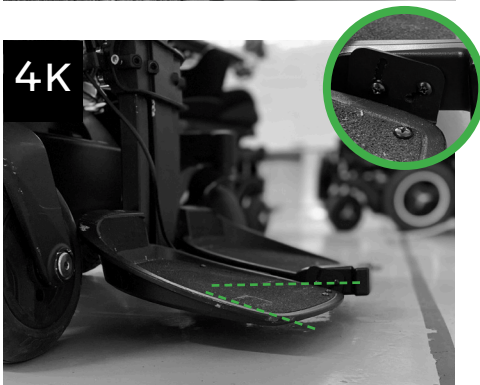
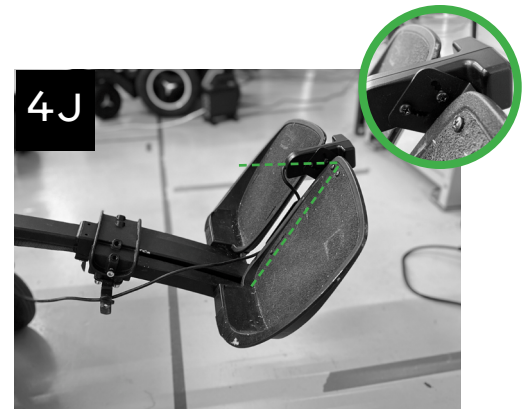
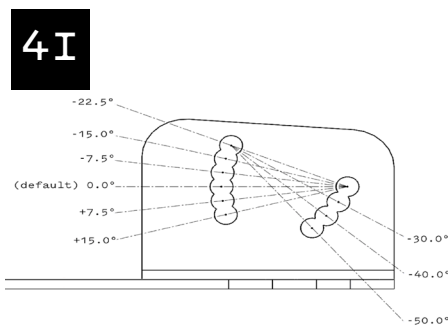

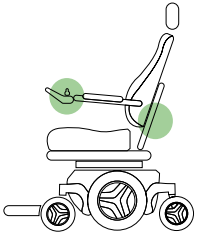

STEP 5 - INSTALL LUCI RNET ADAPTER AND DASHBOARD

Follow the appropriate steps based on the wheelchair's drive method:

- Step 5A: Standard Joystick
- Step 5B: Alternative Drive With Omni Module

STEP 5A - STANDARD JOYSTICK

Tools Required

- LUCI RNET Adapter Cable Kit (D)
- Dashboard (E)
- Standard (Joystick) Dashboard Bracket (G)
- Dashboard Reference Card (F)
- 4-40 x 3/16 Inch Screws (O)
- Zip Ties (Q)
- 3mm Allen Wrench
- 2.5mm Allen Wrench
- Zip Tie Snips
- Flathead Screwdriver
- Phillips Screwdriver

Remove the backrest cover by pulling it up and tilting it out (Figure 5A) to access the RNET hub. Pro Tip: insert the backrest adjustment tool in the space on the side to pull the cover up before tilting it.

Use a 3mm Allen wrench to remove the joystick module. Unplug the right-angle male RNET cable from the back of the joystick module (Figure 5B). You may need a small flathead screwdriver to pry the cable out. Remove the cable from the wheelchair - you will need to snip some zip ties and may need to open the plastic cover on the armrest using a 2.5mm Allen wrench (Figure 5C).

Unplug the other end of the RNET cable from the hub on the back of the wheelchair (Figure 5D). Set this cable aside. Now, plug the right-angle end of the LUCI RNET Adapter Cable (D) into the joystick module (Figure 5E).

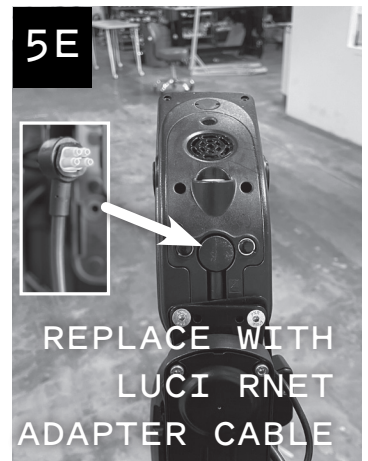
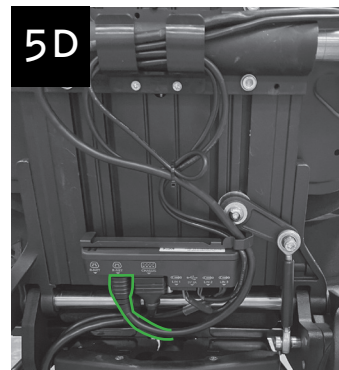
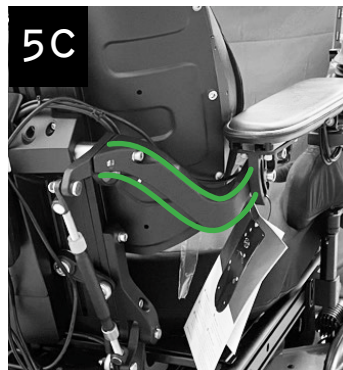
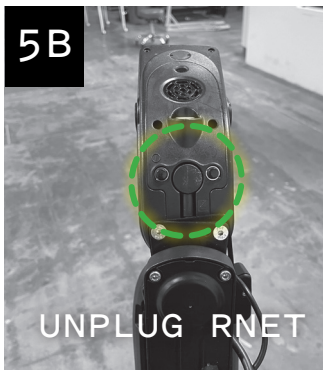
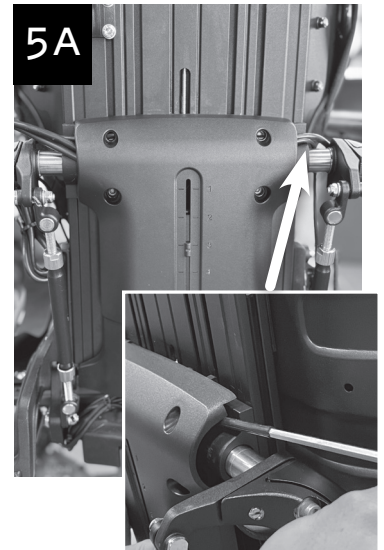

Choose the correct (left or right) Dashboard Reference Card (F). Use four 4-40 x 3/16 inch screws (O) to attach the Standard Joystick Dashboard Bracket (G) to the back of the LUCI Dashboard (E), sandwiching the Dashboard Reference Card (F) between them and ensuring the cable is routed correctly (Figure 5F).

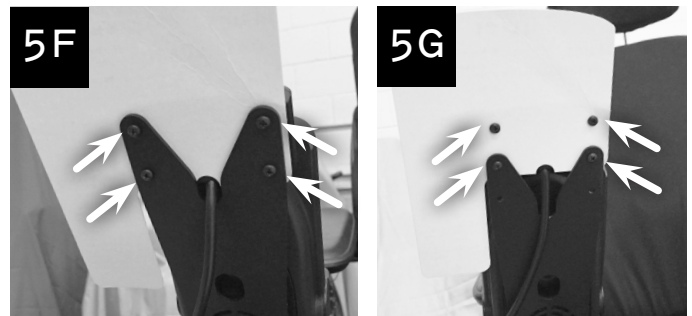

i Note that for newer wheelchairs, the joystick module is taller, so the bottom two holes on the Dashboard should be attached to the top two holes on the bracket; insert screws into the top two holes on the Dashboard to ensure the unit stays sealed (Figure 5G).



Insert the Dashboard bracket between the armrest and the joystick module and reinsert the screws (Figure 5H).

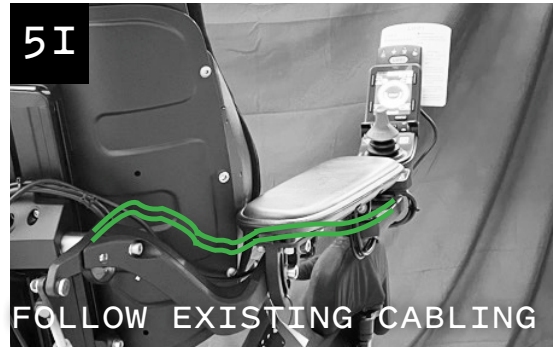

Route the LUCI RNET Adapter Cable (D) and the Dashboard (E) cable along the armrest toward the back of the wheelchair. Follow existing cabling and zip tie (Q) as needed (Figure 5I).

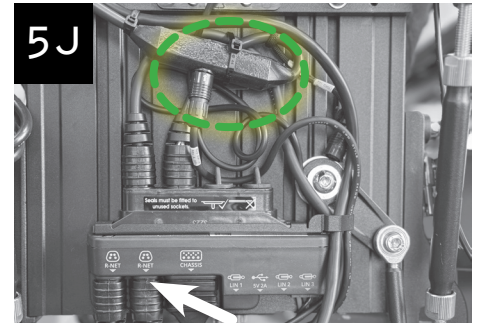

Plug the LUCI RNET Adapter Cable (D) into the RNET hub. Use the cable tie mount and a zip tie to secure the adapter portion of the LUCI RNET Adapter Cable in place (Figure 5J).

STEP 5B - ALTERNATIVE DRIVE WITH OMNI MODULE

Tools Required

- LUCI RNET Adapter Cable Kit (D)
- Dashboard (E)
- Dashboard Reference Card (F)
- Alternative Drive Dashboard Bracket (H)
- 4-40 x 3/16 Inch Screws (O)
- M5 x 8mm Hex Head Screws (N)
- Zip Ties (Q)
- 3mm Allen Wrench
- Zip Tie Snips
- Phillips Screwdriver

Remove the cover of the Omni module on the back of the wheelchair to access the cables (Figure 5K).

Unplug the right-angle RNET cable plugged into the side of the Omni module (Figure 5L).

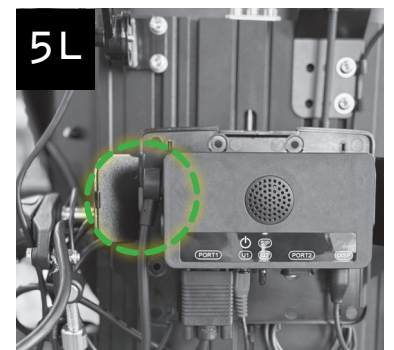
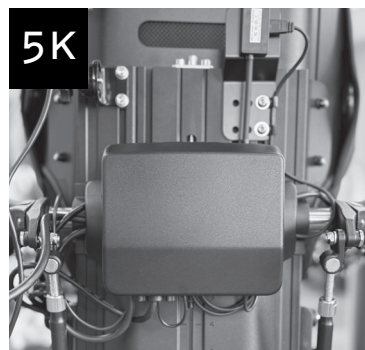

Use a 3mm Allen wrench to remove the top plate of the backrest (Figure 5M). Loosen the bolts and slide the Omni module and bracket up to remove it from the backrest.

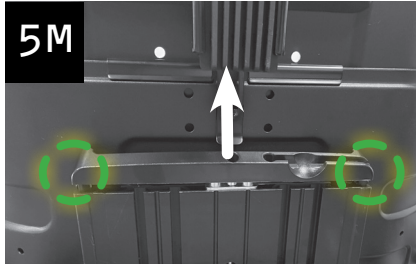

Remove the backrest cover by pulling it up and tilting it out (Figure 5N) to access the RNET hub. Pro Tip: insert the backrest adjustment tool in the space on the side to pull the cover up before tilting it out.

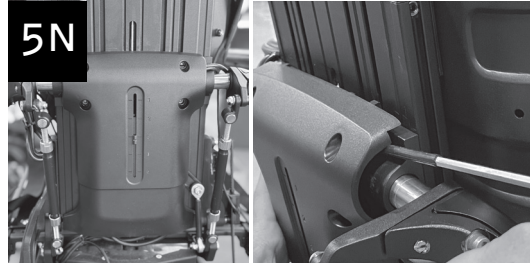

Continue removing the RNET cable from the wheelchair. Unplug the other end of the RNET cable from the hub on the back of the wheelchair (Figure 5O).

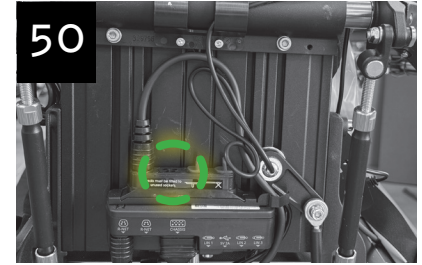

Replace the RNET cable that was removed with the LUCI RNET Adapter Cable (D), plugging the right-angle end into the Omni module. Use the cable tie mount and a zip tie to secure the adapter portion near the hub (Figure 5P).



Choose the correct (left or right) Dashboard Reference Card (F). Use four 4-40 x 3/16 inch screws (O) to attach the Alternative Drive Dashboard Bracket (H) to the back of the LUCI Dashboard (E), sandwiching the Dashboard Reference Card (F) between them, and ensuring the cable is routed correctly (Figure 5Q).



Attach the Alternative Drive Dashboard Bracket (H) to the Omni module using M5 x 8mm hex head screws (N) (Figure 5R). Note that newer Omni modules are taller and will require use of the lower screw holes. Follow existing cabling to route the Dashboard (E) cable toward the back of the wheelchair and use zip ties (Q) to attach cables along the way.

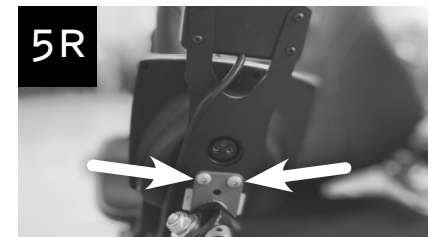

i Note: For alternative drive wheelchairs, the Dashboard (E) includes an auxiliary jack. Any momentary switch plugged into the jack can be used as the override button. If not used, be sure to keep the dust plug in the jack.

⚠ Caution: All cables should be installed, bundled and routed so as to avoid damage to the cables through pinching, dragging, etc. and to avoid excess cable length that could lead to entanglement or strangulation.

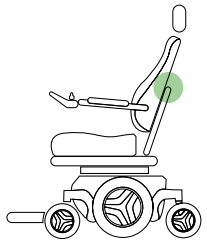

STEP 6 - ATTACH LUCILINK HUB

Tools Required

- Alcohol Wipe (P)
- Zip Ties (Q)
- LuciLink Hub (I)

Use the alcohol wipe (P) to clean a flat area on the wheelchair seat back.

i Note: We recommend placing the LuciLink Hub in the upper left or upper right of the seat back (Figure 6A). The LuciLink Hub may be placed anywhere on the seat back, as long as it does not limit the range of motion of the seat, armrests, etc. (Figure 6B)

Remove the Velcro backing from the LuciLink Hub (I) back cover and affix it to the cleaned area, so that the key is oriented as shown and the cable opening is at the bottom (Figures 6A and 6B).

i Note: If the wheelchair seat raises and lowers, raise the seat to its fullest extent.

Starting at the back of the wheelchair, begin routing the two cables that exit the LUCI unit - the USB Extension Cable and the LUCI RNET Cable - toward the LuciLink Hub (I) (Figure 6C).

Route the cables toward the front of the wheelchair first (Figure 6D), then follow existing cabling along the seat mechanism, zip tying the cables as needed (Figure 6E).

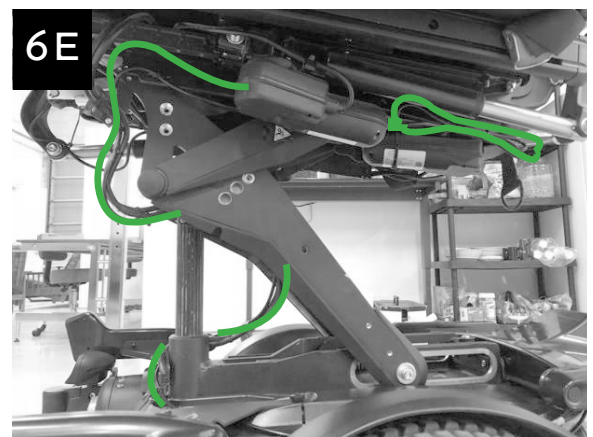
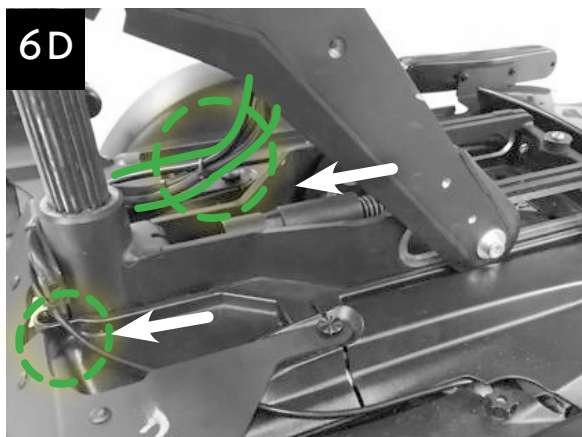
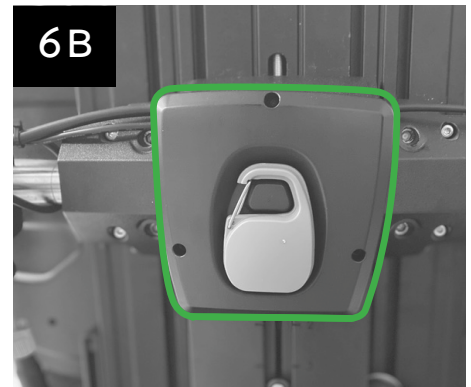
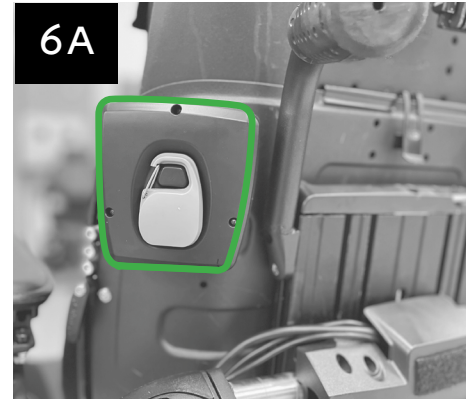

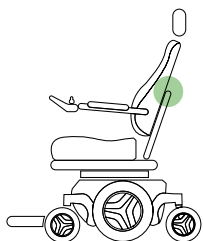

STEP 7 - CONNECT LUCI

No Tools Required

Remove the plug from the adapter portion of the LUCI RNET Adapter Cable (D) by gripping the connector and pulling it straight out (Figure 7A). Plug the LUCI RNET Cable into the port on the adapter.

⚠ Caution: All cables should be installed, bundled and routed so as to avoid damage to the cables through pinching, dragging, etc. and to avoid excess cable length that could lead to entanglement or strangulation.

Reinstall the cover on the backrest (Figure 7B). If the wheelchair has an Omni module, reinstall the module on the backrest, and reattach the cover and top plate.

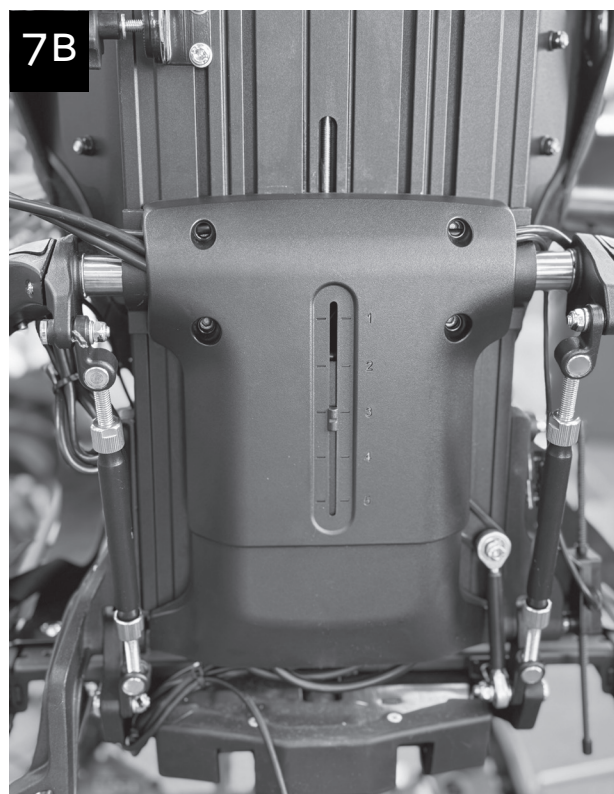
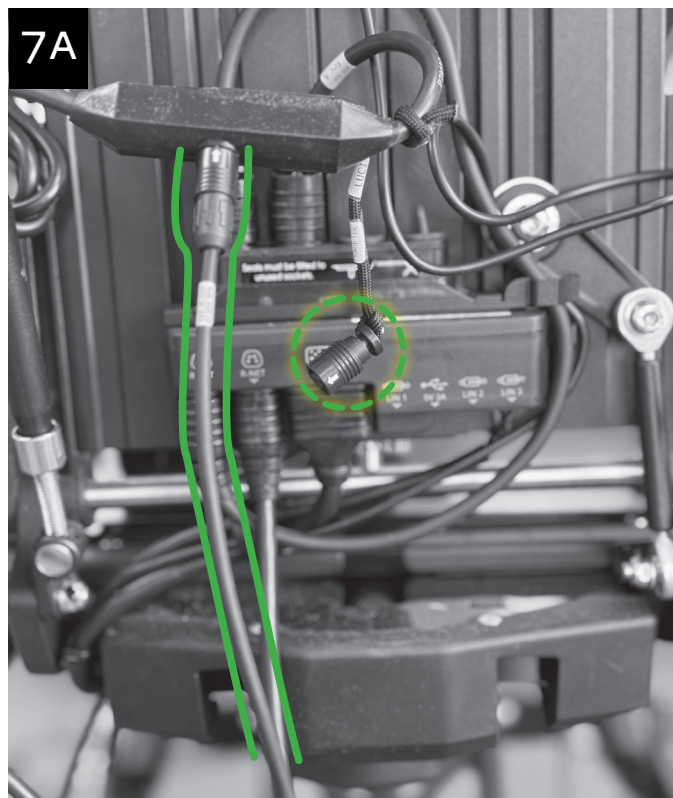

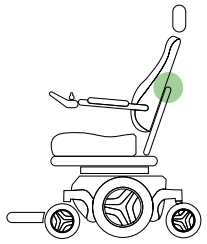

STEP 8 - PLUG IN USB CABLES

Tools Required

- Phillips P1 Screwdriver
- Zip Tie Snips

Using a Phillips P1 screwdriver, remove the front cover of the LuciLink Hub (I) to expose the USB hub inside (Figure 8A).

Plug the Scout (B) and Dashboard (E) USB cables into the hub (Figure 8B).

Connect the LUCI USB Extension Cable to the hub cable (Figure 8C). Ensure all cables are securely seated inside the LuciLink Hub and do not interfere with the screw holes (Figure 8C).

Reattach the front cover of the LuciLink Hub (Figure 8D).

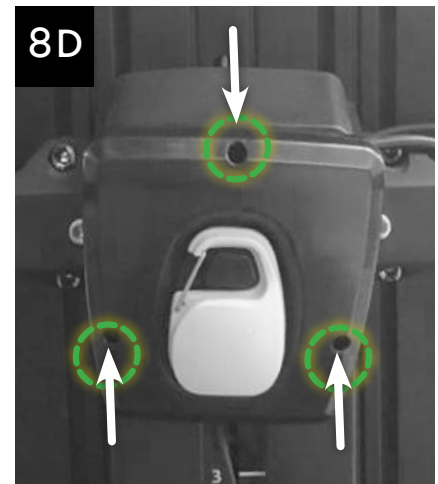
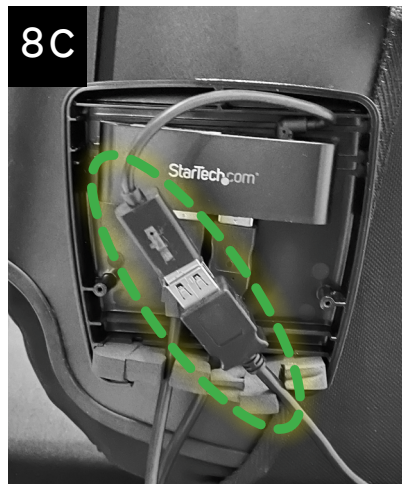
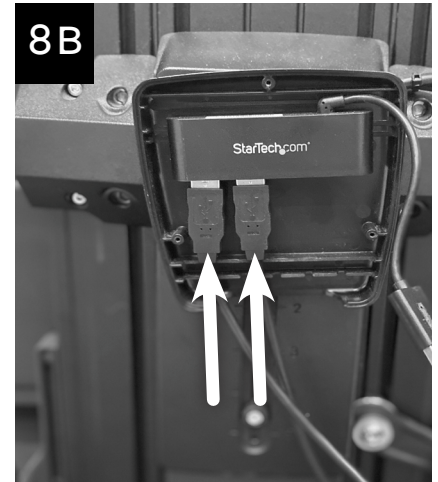

⚠ Caution: All cables should be installed, bundled and routed so as to avoid damage to the cables through pinching, dragging, etc. and to avoid excess cable length that could lead to entanglement or strangulation.

⚠ Caution: If the driver typically uses backpacks or hangs other bags off his/her wheelchair, suggest the user clip the Wheelchair Key to a different location on the wheelchair to avoid knocking it out of its magnetized place on the LuciLink Hub (B).

⚠ Caution: Clip all the zip ties to remove any dangling ends.

ONCE LUCI IS INSTALLED:

- Power on the wheelchair and ensure that the seat, armrests, and footrest are able to move to their full extent without pinching or pulling any cables, or compressing any parts of LUCI.
- Ensure that leg pads and UniTrack accessories, such as lateral thigh supports, do not contact or block the front camera pods and/or headlights at the lowest seat elevation.
- Confirm the Dashboard Reference Card is attached to the LUCI Dashboard.
- Check that there are no loose, pinched or dragging cables.
- Confirm the Sensor Status light on the Dashboard is orange (demo mode).
- Press the LUCI button and make sure the LUCI button lights up blue, the chair can move in each direction when clear, and the chair stops in a blocked direction of travel.

Before releasing the wheelchair to the user, the system will need to be configured. With the user in the wheelchair, follow the instructions in the LUCI Quick Start Guide.

CONGRATULATIONS,
you have installed

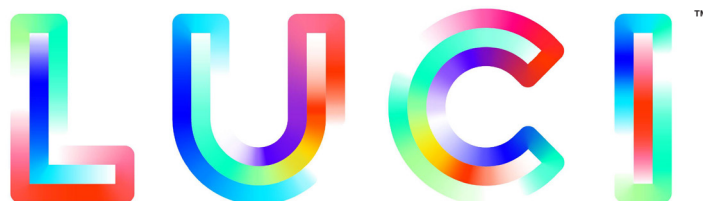

Copyright © 2024 LUCI, All Rights Reserved.

All product names, brands, and trademarks are property of their respective owners. All company, product, and service names used are for identification purposes only. Use of these names, trademarks, and brands does not imply endorsement.

For more information on our patents, please visit luci.com/patents

LUCI™

LUCI.COM

613-00001 Rev B
March 2024 or later