

INSTALLATION GUIDE
AMY R3



INSTALLATION GUIDE

AMY R3

PACKAGE CONTENTS

- A. Rear SmartFrame™ (1)
- B. Front Left SmartFrame™ (1)
- C. Front Right SmartFrame™ (1)
- D. Left Side SmartFrame™ (1)
- E. Right Side SmartFrame™ (1)
- F. 2m Male-to-Male RNET Extension Cable (1)
- G. Scout Kit (1)
- H. Footplate Drill Guide (1)
- I. Scout Cable Guide Plate (1)
- J. Dashboard (1)
- K. Dashboard Reference Card (2)
- *Bracket based on order form:*
 - L. LED Joystick Dashboard Bracket (1)
 - M. Color Joystick Dashboard Bracket (1)
 - N. Color Joystick Spacer (1)
 - O. CJSM 1/2 Dashboard Bracket (1)
 - P. OMNI Dashboard Bracket (1)
- Q. Rear Cover (1)
- R. LuciLink™ Hub & Wheelchair Key™ (1)
- S. M8 x 25mm Bolt (8)
- T. M8 x 12mm Bolt, blue (1)
- U. M5 x 8mm Button Flange Head Screw (12)
- V. M5 x 16mm Socket Head (1)
- W. M5 x 16mm Hex Head Screw (2)
- X. 10-32 x 3/8 Hex Head Screw (4)
- Y. M5 x 8mm Hex Head Screw (2)
- Z. #6 x 1/2 Self Tapping Screw (3)
- AA. 4-40 x 3/16 Philips Head Screw (4)
- AB. #10 Washer (1)
- AC. 3/16" Cable Clamp (1)
- AD. Alcohol Wipe (3)
- AE. 3/16" Drill Bit (1)
- AF. Cable Clips
- AG. Zip Ties
- AH. User Manual

You will also need:

- 3mm Allen Wrench
- 4mm Allen Wrench
- 5mm Allen Wrench
- 13mm Socket Wrench
- Ratchet Extension
- Phillips P1 Screwdriver
- Masking Tape
- Drill
- Zip Tie Cutter

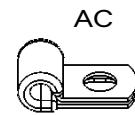
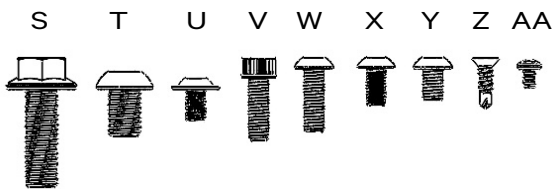
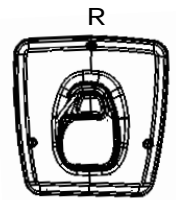
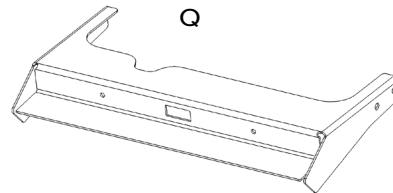
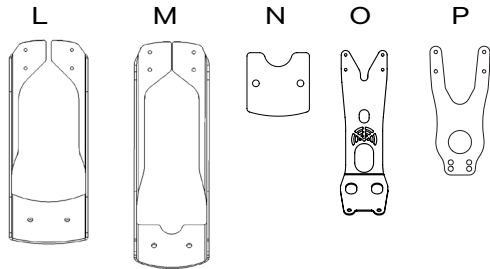
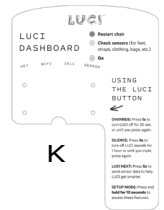
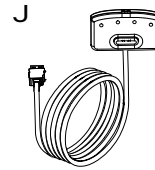
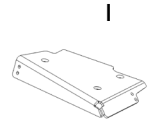
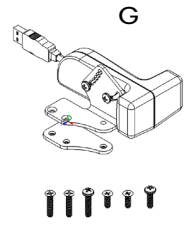
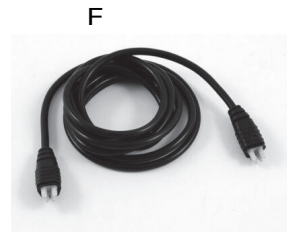
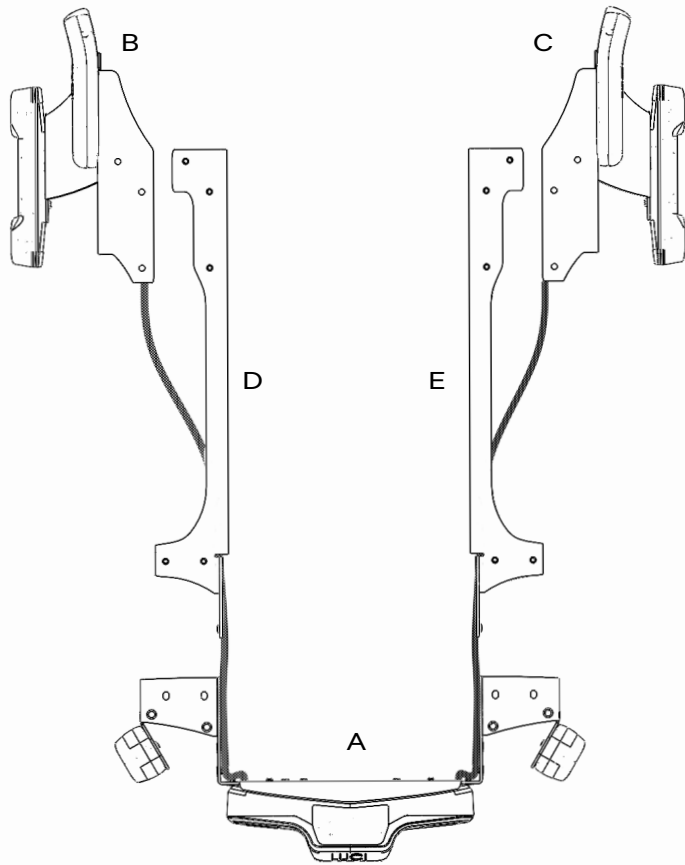

INSTRUCTIONS



STEP 1 - PREPARE WHEELCHAIR BASE

Tools Required

- Rear SmartFrame™ (A)
- Front Left SmartFrame™ (B)
- Front Right SmartFrame™ (C)
- M8×25mm Bolts (S)
- M8×12mm Bolt, blue (T)
- Ratchet Extension
- 13mm Socket Wrench
- 3mm Allen Wrench
- 5mm Allen Wrench

Place the Rear, Left and Right SmartFrames (A, B and C) around the wheelchair (Figure 1A). Put the backrest in the full upright position. If the wheelchair has a seat elevator, raise the seat for easier access. Power the wheelchair off. Working one bolt at a time, remove all the seating assembly bolts from the railing on the back of the chair on both sides with a 13mm socket wrench (Figure 1B). Replace each bolt with an M8 x 25mm bolt (S) and leave the bolts loosely inserted (Figure 1C).

i Note: If the wheelchair has tilt only, there will be four bolts on each side, two near the front, two near the back; if it has elevate and tilt, there will only be two bolts total on each side.

Remove the rear reflector cable cover by pulling the slot on the cover over the metal retaining tab (Figure 1D).

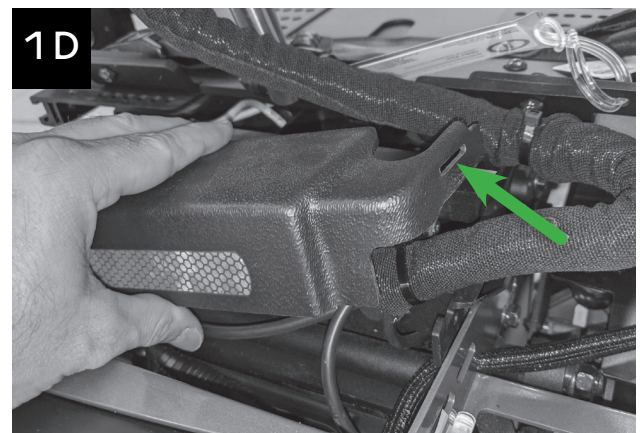
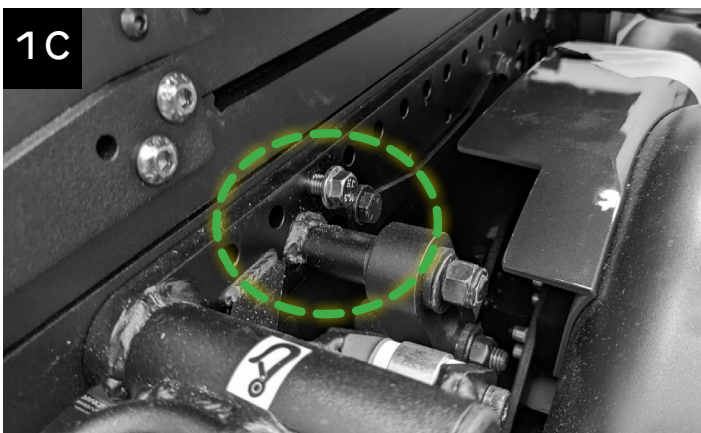
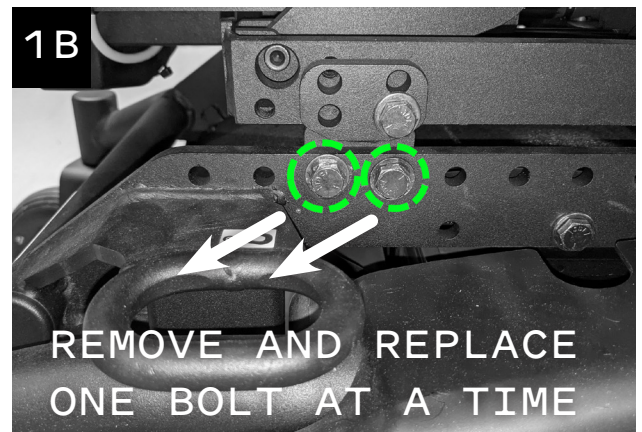

FOR WHEELCHAIR WITH TILT-ONLY

Use a 3mm Allen wrench to remove the rear cover mounting bracket (Figure 1E). Repeat on the other side of the wheelchair.



FOR WHEELCHAIR WITH SEAT ELEVATOR

Beginning on the right side of the chair, use a 13mm socket wrench to remove the rear cover mounting bracket (Figure 1F). Remove and set aside the thinner, outer bracket. Reattach the thicker, inner bracket with the original M8 bolts in the forward holes. Replace the rear bolt with one M8 x 12mm blue-dyed bolt and tighten with a 5mm Allen wrench (Figure 1G). Repeat on the other side of the wheelchair, using the original M8 bolts in all three holes.

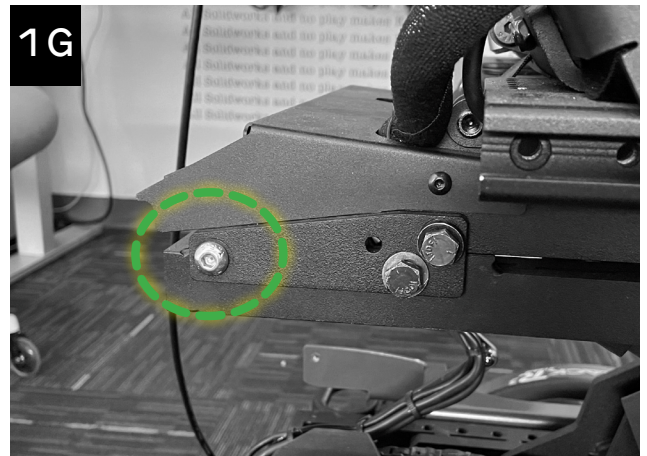
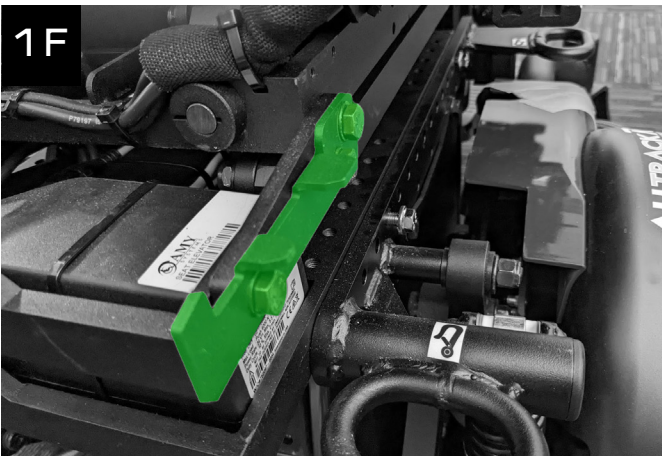

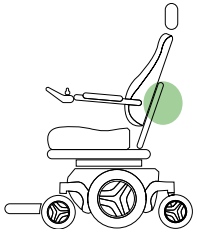

STEP 2 - PREPARE FOR CABLE ROUTING

Tools Required

- 2m RNET Male-to-Male Extension Cable (F)
- Zip Tie Cutter

Plug one end of the 2m Male-to-Male RNET Extension Cable (F) into one of the RNET cables coming out of the LUCI Rear Smart-Frame (A) (Figure 2A). Remove the backrest cover of the wheelchair by lifting the slots in the cover over the retaining tabs (Figure 2B).

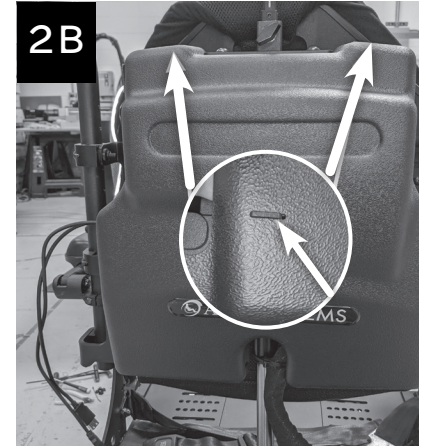
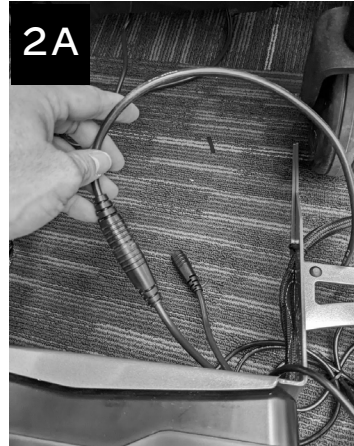

FOR WHEELCHAIR WITH SEAT ELEVATOR

If the wheelchair is equipped with a seat elevator, remove the zip ties from the cable guide bracket (Figure 2C). Separate the RNET cable coming from the bottom of the chair (Figure 2D).

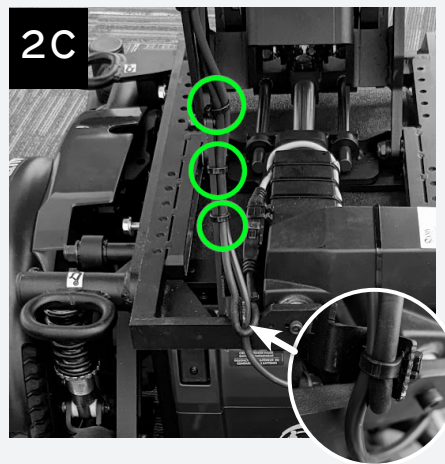

i Note: It may be helpful to take a picture of the wire routing before removing zip ties and cable cover, to reference when re-routing.

Remove all remaining zip ties on the cable bundle from the base to the back of the chair. Remove the fabric cover from the cable bundle. Follow the RNET cable up to the seating controller and unplug it. Separate this cable from the bundle and set it down behind the wheelchair.



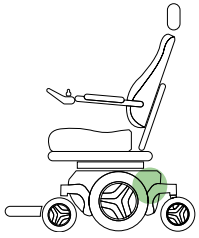

STEP 3 - SECURE THE SIDE SMARTFRAMES

Tools Required

- Rear SmartFrame™ (A)
- Left Side SmartFrame™ (D)
- Right Side SmartFrame™ (E)
- 13mm Socket Wrench
- Ratchet Extension

Set the Left Side SmartFrame (D) in place, slotting it onto the loosely inserted M8 x 25mm bolts from Step 1 (Figure 3A). The frame should sit as far back as possible, and the front two half-circles should line up with the front two holes over the tie-downs (Figure 3B). Confirm that the frame is level and tighten the bolts with a 13mm socket wrench. Repeat on the other side with the Right Side SmartFrame (E).

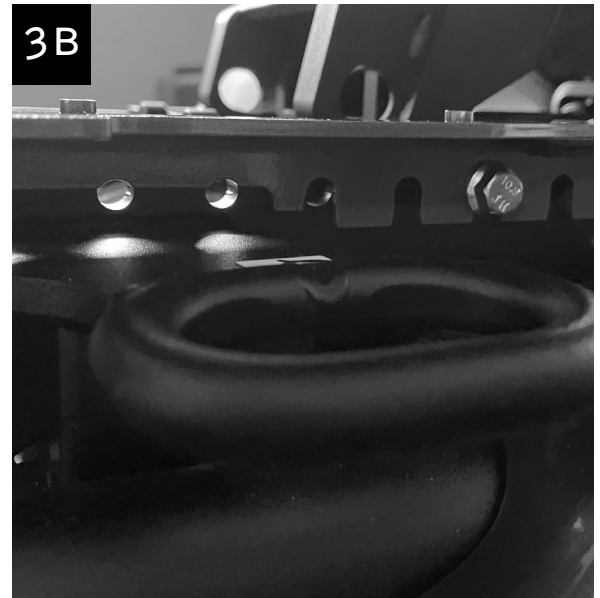

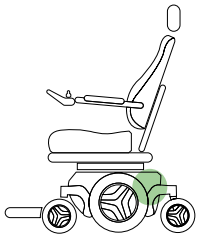

STEP 4 - SECURE REAR SMARTFRAME

Tools Required

- Rear SmartFrame™ (A)
- Front Left SmartFrame™ (B)
- Front Right SmartFrame™ (C)
- M5 × 8mm Flange Screws (U)
- 3mm Allen Wrench

Set the Front Left SmartFrame (B) and Front Right SmartFrame (C) on the wheelchair and set the Rear SmartFrame (A) onto the side frames. Pull the RNET extension cable (F) that was plugged into LUCI, along with the USB extension cable that exits the Rear SmartFrame (A) up and over the Rear SmartFrame. Pull the original RNET cable (which was set behind the wheelchair at the end of Step 2) through to the bottom below the Rear SmartFrame (A). Make sure the cable bundle that connects the Front and Rear SmartFrames is routed under the Side SmartFrames and clip in the three standoffs on each side (Figure 4A).



Insert three M5 x 8mm Flange Head Screws (U) on each side to secure the Rear SmartFrame (A) to the side frames (Figure 4B). Tighten with a 3mm Allen wrench.



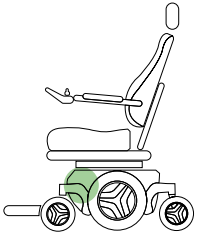

STEP 5 - SECURE SIDE SMARTFRAMES

Tools Required

- Front Left SmartFrame™ (B)
- Front Right SmartFrame™ (C)
- M5 × 8mm Flange Screws (U)
- 3mm Allen Wrench
- Zip Ties (AG)

Press the Front Right SmartFrame (C) onto the three standoffs on the Right Side SmartFrame (E) so that it clips into place (Figure 5A). Insert three M5 x 8mm Flange Head Screws (U) and tighten with a 3mm Allen wrench (Figure 5B). Repeat on the other side to secure the Front Left SmartFrame (B) to the Left Side SmartFrame (D).

Insert zip ties (AG) into the cable tie mounts below the Left and Right Side SmartFrames, two on each side. Pull any excess cable to the rear and zip tie the cable bundles to the SmartFrames (Figure 5C).

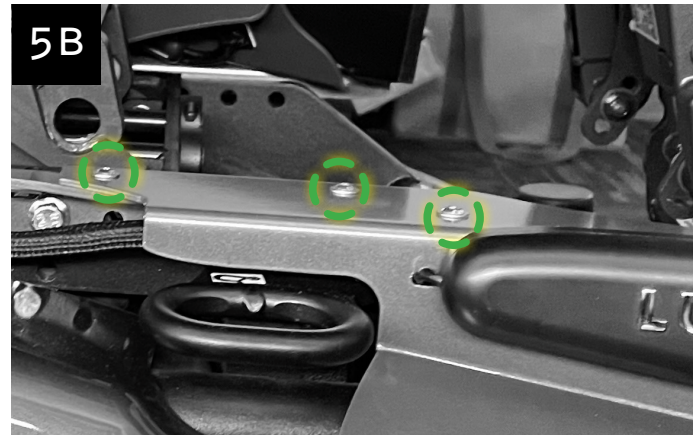

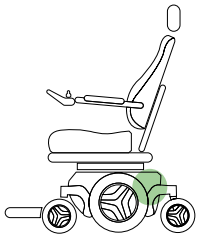

STEP 6 - FINISH ROUTING CABLES

Tools Required

- Zip Ties (AG)

Leaving a few inches of slack near the rear Smart Frame, start running the new RNET Extension Cable (F) and LUCI USB extension cable up through the cable guides. The bottom actuator cable and USB cable should be on the left of the lower cable guide and the RNET extension should be on the right side (Figure 6A). All the cables should move to the left side of the cable guide levers after the first zip tie. Zip tie (AG) the cables at the original locations. The top zip tie near the guide hinge holds just the cables together and is not tied to the lever mechanism (Figure 6B). Feed the cables back through the fabric cable cover (Figure 6C). Zip tie the cable bundle back into place (Figure 5C). Plug in the RNET cable to the same port the old cable was unplugged from. Bundle and zip tie (AG) excess cable. The USB cable should exit the bundle just as the bundle reaches the seat actuator (Figure 6D). Plug the original RNET cable into the other RNET cable on the Rear SmartFrame (A) and zip tie the excess cable up out of the way behind the Rear SmartFrame.

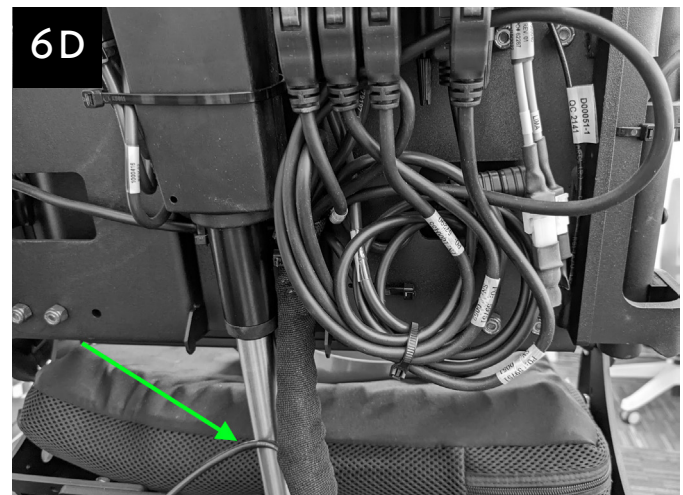
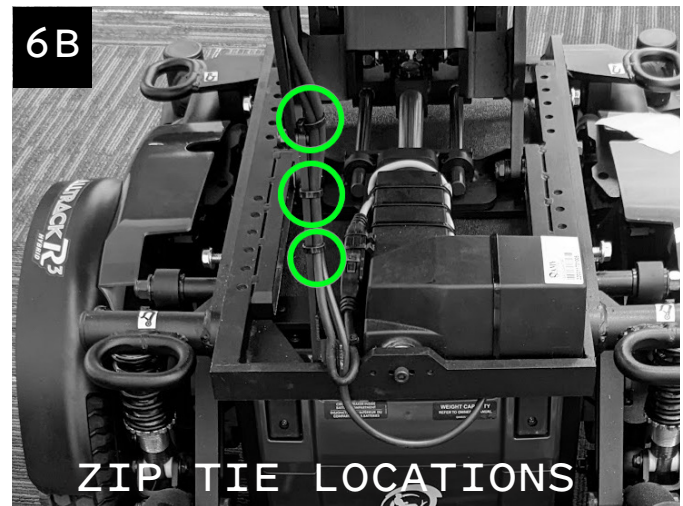
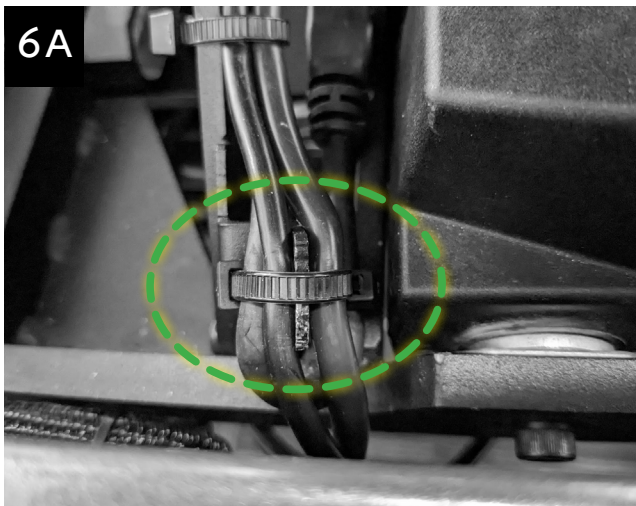

STEP 7 - INSTALL THE DASHBOARD

i Note: To install the Dashboard, you will need to select the correct Dashboard Bracket depending on the wheelchair's drive system:

- | | | |
|--------------------------|--|-----------|
| - LED Joystick | - LED Joystick Dashboard Bracket (L) | - Step 7A |
| - Color Joystick | - Color Joystick Dashboard Bracket (M) | - Step 7B |
| - Standard Joystick | - CJSM 1/2 Dashboard Bracket (O) | - Step 7C |
| - Omni Alternative Drive | - Omni Dashboard Bracket (P) | - Step 7D |

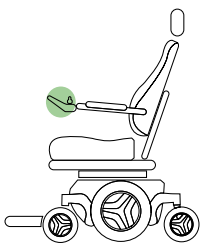

STEP 7A - LED JOYSTICK

Tools Required

- | | |
|--------------------------------------|------------------------------------|
| - Dashboard (J) | - 3mm Allen Wrench |
| - Dashboard Reference Card (K) | - 4mm Allen Wrench |
| - LED Joystick Dashboard Bracket (L) | - 5mm Allen Wrench |
| - Phillips P1 Screwdriver | - M5×16mm Hex Screws (W) |
| | - 4-40 × 3/16 Phillips Screws (AA) |

i Note: There are several types of joystick brackets. Solid mount is shown in this step. For ball mount, refer to relevant instructions in step 7B.

Remove the joystick module from the armrest of the wheelchair by removing the M6 screws using a 4mm Allen wrench (Figure 7A1). Using a Phillips screwdriver, remove the two screws holding the T-bracket to the joystick module (Figure 7A2). Choose the correct (left or right) Dashboard Reference Card (K). Use four 4-40 x 3/16 inch screws (AA) to attach the LED Joystick Dashboard Bracket (L) to the back of the Dashboard (J), with the Dashboard Reference Card (K) behind the bracket (Figure 7A3). Route the Dashboard cable along the lower inside bend of bracket and place the joystick module inside the Bracket. Reinstall the T-bracket with the short side facing the front of the joystick (Figure 7A4). Reattach the entire joystick module to the wheelchair arm and tighten the original M6 screws with a 4mm Allen wrench.

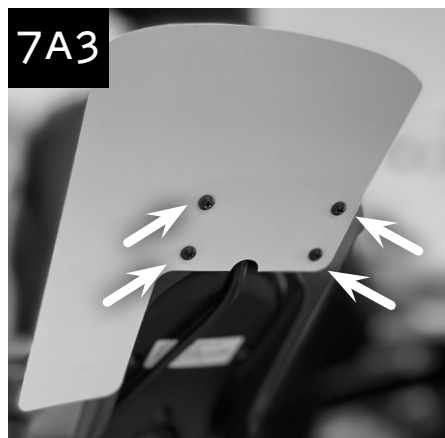
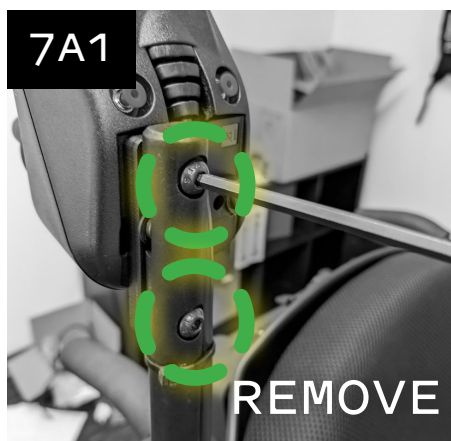

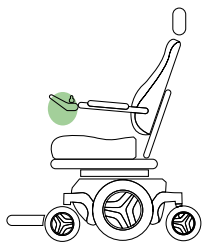

STEP 7B - COLOR JOYSTICK

Tools Required

- | | |
|--|------------------------------------|
| - Dashboard (J) | - 3mm Allen Wrench |
| - Dashboard Reference Card (K) | - 4mm Allen Wrench |
| - Color Joystick Dashboard Bracket (M) | - 5mm Allen Wrench |
| - Color Joystick Spacer (N) | - Phillips P1 Screwdriver |
| | - M5×16mm Hex Screws (W) |
| | - 4-40 × 3/16 Phillips Screws (AA) |

i Note: There are several types of joystick brackets. Ball mount is shown in this step. For solid mount, refer to relevant instructions in step 7A.

Remove the joystick module from the armrest of the wheelchair by removing the M6 screw using a 5mm Allen wrench (Figure 7B1). Using a 4mm Allen wrench, remove the three bolts holding the ball retainer in place and remove the ball retainer (Figure 7B2). Using a 3mm Allen wrench, remove the two screws holding the bracket to the joystick module (Figure 7B3).

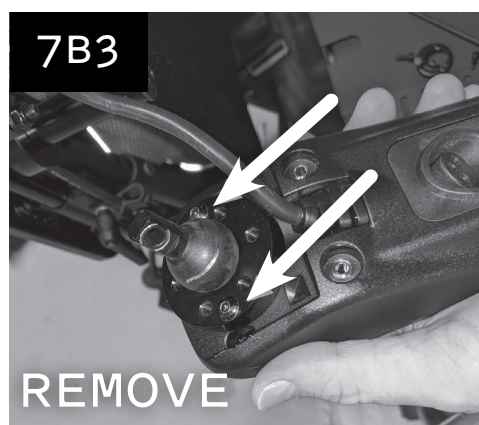
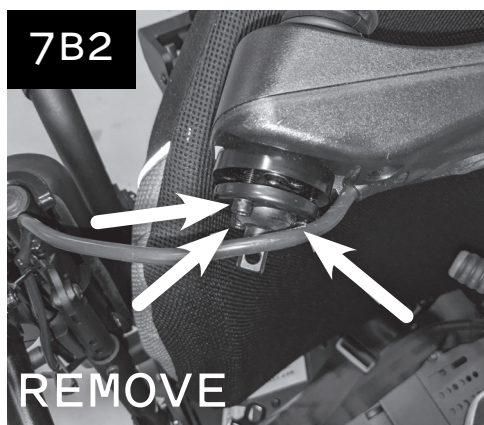
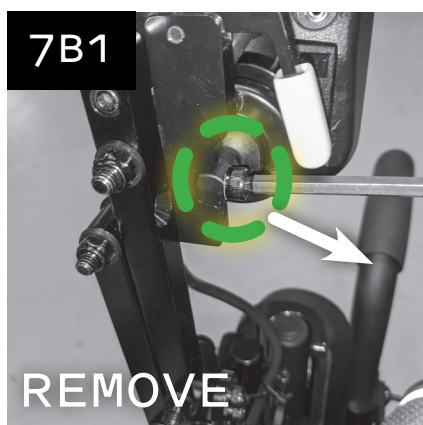

Feed the joystick cable through the split in the Color Joystick Bracket (M) (Figure 7B4). Choose the correct (left or right) Dashboard Reference Card (K). Use four 4-40 x 3/16 inch screws (AA) to attach the LED Joystick Dashboard Bracket (M) to the back of the Dashboard (J), with the Dashboard Reference Card (K) behind the bracket (Figure 7B5). Route the Dashboard cable along the lower inside bend of bracket and place the joystick module inside the bracket. Turn the joystick module upside down, and slide the Color Joystick Spacer (N) in between the joystick module and the bracket (Figure 7B6). Insert two M5 x 16mm hex head screws (W) to reattach the ball retainer to the joystick module, tightening them with a 3mm Allen wrench (Figure 7B7). Place the ball into the bottom bracket and place the retaining bracket over it. Orient the longer end of the opening toward the curved end of the dashboard bracket and reinstall the three original screws (Figure 7B8). Make sure to tighten the screws evenly so that the retaining bracket is level with the bottom bracket (Figure 7B8). Reattach the entire joystick module to the wheelchair arm and tighten the original M6 screw with a 5mm Allen wrench (Figure 7B9).

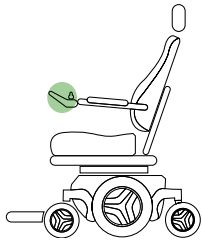
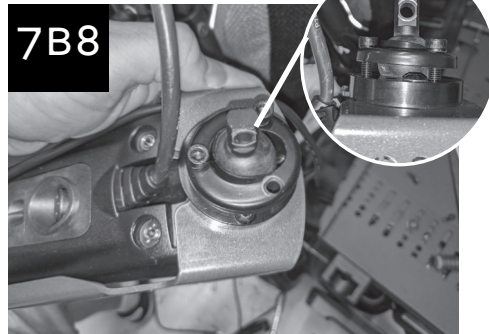
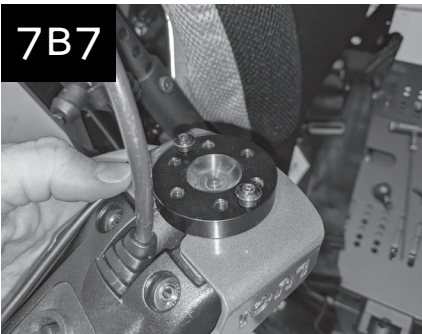
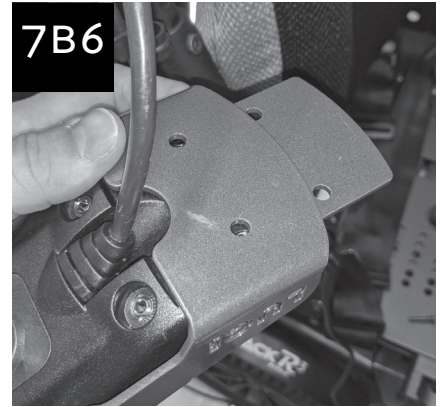
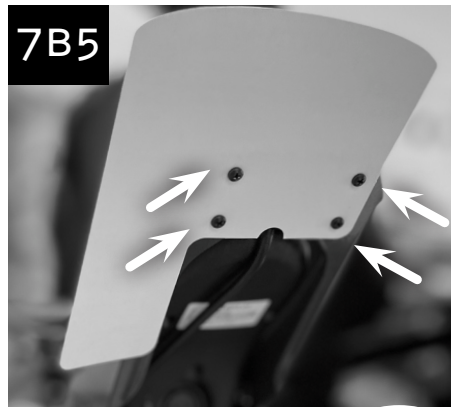
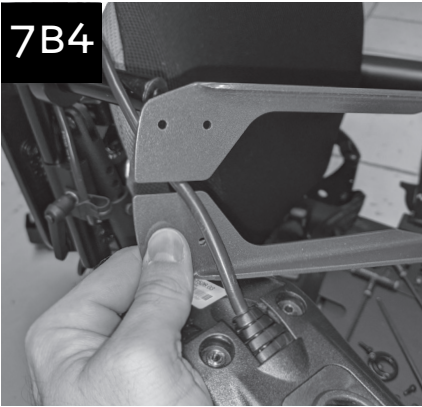

STEP 7C - CJSM 1/2 JOYSTICK

Tools Required

- Dashboard (J)
- Dashboard Reference Card (K)
- CJSM 1/2 Joystick Dashboard Bracket (O)
- 3mm Allen Wrench
- 5mm Allen Wrench
- Phillips P1 Screwdriver
- 4-40 x 3/16 Phillips Screws (AA)
- Zip Tie (AG)

Choose the correct (left or right) Dashboard Reference Card (K). Use four 4-40 x 3/16 inch screws (AA) to attach the bracket to the back of the Dashboard (J), sandwiching the Dashboard Reference Card (K) between them and ensuring the cable is routed correctly (Figure 7C1 or 7C2).



Note that for newer wheelchairs, the joystick module is taller, so the Dashboard should only be attached to the top two holes on the bracket; insert screws into the top two holes on the Dashboard (J) to ensure the unit stays sealed (Figure 7C2). Remove the joystick module from the armrest of the wheelchair by loosening the M6 screw using a 5mm Allen wrench. Use a 3mm Allen wrench to remove the metal bracket from the joystick module. Insert the Dashboard bracket between the armrest and the joystick module and reinsert the screws (Figure 7C3). Route and zip tie (AG) the cable as shown (Figure 7C3). Reattach the joystick module and tighten the original M6 screw.

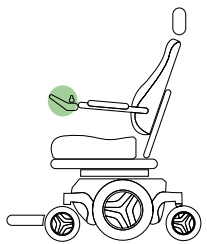
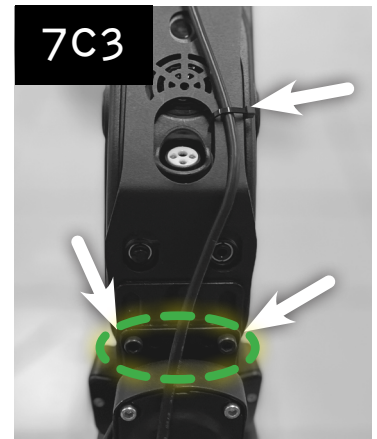

STEP 7D - OMNI ALTERNATIVE DRIVE

Tools Required

- | | |
|--------------------------------|------------------------------------|
| - Dashboard (J) | - 3mm Allen Wrench |
| - Dashboard Reference Card (K) | - Phillips P1 Screwdriver |
| - Omni Dashboard Bracket (P) | - M5 × 8mm Hex Screw (Y) |
| | - 4-40 × 3/16 Phillips Screws (AA) |

Choose the correct (left or right) Dashboard Reference Card (K). Use four 4-40 x 3/16 inch screws (AA) to attach the bracket to the back of the Dashboard (J), sandwiching the Dashboard Reference Card (K) between them and ensuring the cable is routed correctly (Figure 7D1). Use a 3mm Allen wrench to remove the Omni module. Insert the Dashboard bracket between the armrest and the Omni module and attach using two M5 x 8mm hex head screws (Y) (Figure 7D2).



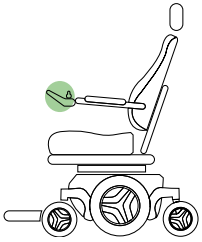

STEP 8 - ROUTE THE DASHBOARD CABLE

Tools Required
- Zip Ties (AG)

Regardless of the type of Dashboard Bracket that was used, route the Dashboard cable toward the back of the wheelchair, following existing cabling and using zip ties (AG) as needed (Figure 8A). Zip tie (AG) the Dashboard and LUCI USB Extension Cable together near the seat actuator so that the ends are roughly lined up (Figure 8B). Zip tie the excess cable up out of the way. Reinstall the rear cover (Figure 8C).

i Note: For alternative drive wheelchairs, the Dashboard (J) includes an auxiliary jack. Any momentary switch plugged into the jack can be used as the override button. If not used, be sure to keep the dust plug in the jack.

▲ Caution: All cables should be installed, bundled and routed so as to avoid damage to the cables through pinching, dragging, etc. and to avoid excess cable length that could lead to entanglement or strangulation.

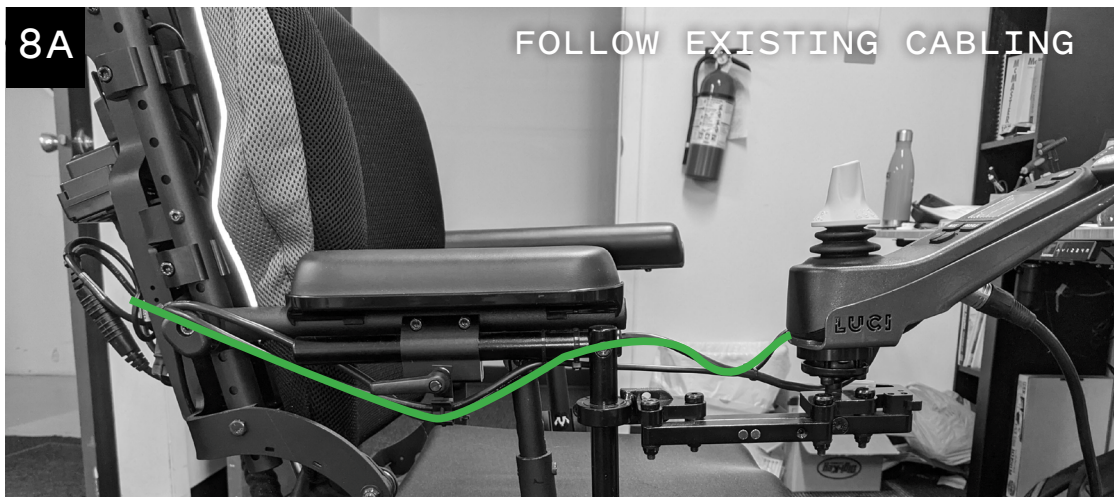

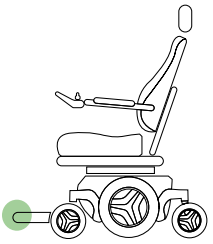

STEP 9A - ATTACH SCOUT (SINGLE FOOTPLATE)

Tools Required

- | | |
|-------------------------------|-----------------------------------|
| - Scout Kit (G) | - Drill |
| - Footplate Drill Guide (H) | - Tape |
| - Scout Cable Guide Plate (I) | - Phillips P1 Screwdriver |
| - 3/16" Drill Bit (AE) | - Screwdriver Bit |
| | - Zip Ties (AG) |
| | - #6 x 1/2 Self Tapping Screw (Z) |

i Note: You will only need the three SHORT screws from the Scout Kit (G), not the three long ones.

Tear out the Footplate Drill Guide (H) along the perforated lines, line it up with the slot as indicated on the template and tape it in place. Drill the hole with the 3/16" Drill Bit (AE) (Figure 9A1). Set the Scout on top of the footplate and line up the Scout lower bracket, holding it in place (Figure 9A2). Loosely insert the two (short) flathead M4 x 14mm screws from the Scout Kit (G) into the top bracket ensuring that the curve in the footstrap slot lines up with the curve in the top bracket (Figure 9A3). Insert the (short) panhead M4 x 14mm screw from the Scout Kit (G) into the hole that was drilled and tighten all three screws. Thread the Scout USB cable through the footstrap slot and raise the footplate. Zip tie (AG) the USB cable to the Scout Cable Guide Plate (I). Route the USB cable along the wall on the Scout Cable Guide Plate (I) and zip tie (AG) at the end. Use a screwdriver bit in the drill to install three #6 x 1/2 Self Tapping Screws (Z), attaching the Scout Cable Guide Plate (G) to the bottom of the footplate (Figure 9A4).

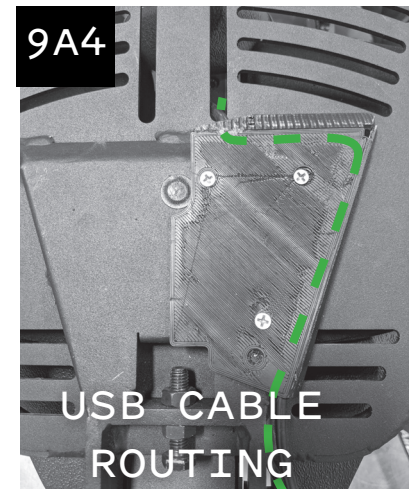
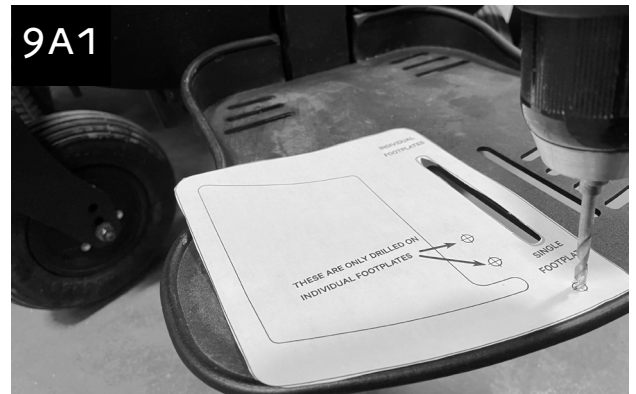

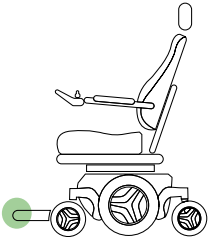

STEP 9B - ATTACH SCOUT (INDIVIDUAL FOOTPLATES)

Tools Required

- Scout Kit (G)
- Footplate Drill Guide (H)
- 3/16" Drill Bit (AE)
- Drill
- Tape
- Phillips P1 Screwdriver
- Zip Ties (AG)

i Note: You will only need the three LONG screws from the Scout Kit (G), not the three short ones.

Tear out the Footplate Drill Guide (H) along the perforated lines, place it on the right footplate, line it up with the slot as indicated on the template and tape it in place. Drill all three holes with the 3/16" Drill Bit (AE) (Figure 9B1). Set the Scout on top of the footplate and line up the Scout lower bracket, holding it in place (Figure 9B2). Loosely insert the two (long) flathead M4 x 20mm screws from the Scout Kit (G) into the top bracket. Insert the (long) panhead M4 x 20mm screw from the Scout Kit (G) into the third hole and tighten all three screws (Figure 9B3). Drill a hole in the side of the right footplate (Figure 9B4) and zip tie (AG) the Scout USB cable through the footstrap slot and the drilled hole (Figure 9B5).

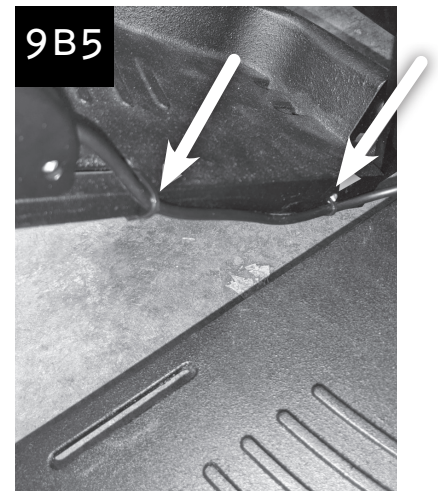
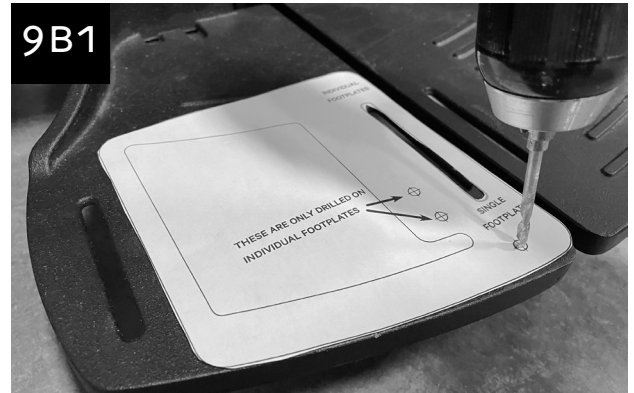

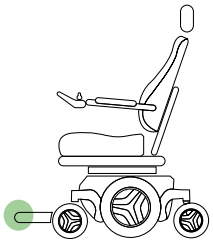

STEP 10 - ROUTE SCOUT CABLE

Tools Required

- 4mm Allen Wrench
- 3/16" Cable Clamp (AC)
- M5x16mm Socket Head Screw (V)
- #10 Washer (AB)
- Alcohol Wipe (AD)
- Cable Clips (AF)
- Zip Ties (AG)

Regardless of the type of footplate, the Scout cable will be routed toward the back of the wheelchair. Just below the calf pad, insert the Scout cable into the 3/16" Cable Clamp (AC) exactly as shown to ensure proper orientation (Figure 10A). Using a 4mm Allen wrench, remove the lower footplate mount screw on the left side. Place the #10 Washer (AB) onto the M5x16mm Socket Head Screw (V), insert the screw into the Cable Clamp (AC) and attach it to the leg rest in place of the screw that was removed, tightening with the 4mm Allen wrench (Figure 10B). Use an Alcohol Wipe (AD) to clean surfaces on the leg rest post (Figure 10C) and place Cable Clips (AF) (Figure 10C).

i Note: Use an alcohol wipe to thoroughly clean the plastic before applying cable clips. Cable clips need firm pressure to properly adhere, and may come off in the first few minutes if moved too aggressively when putting cables into them.

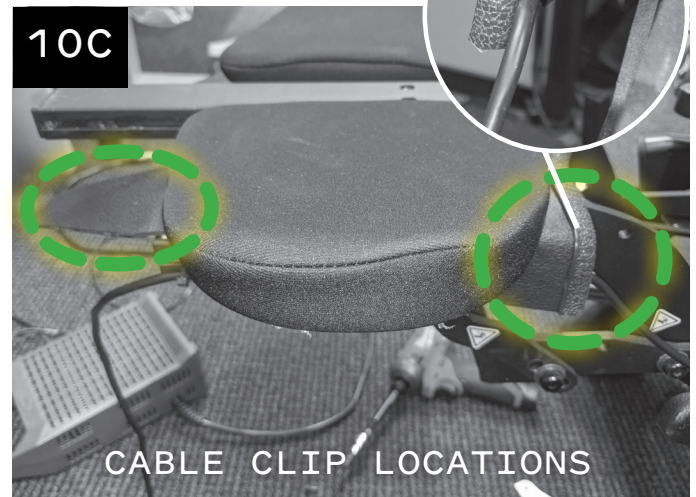
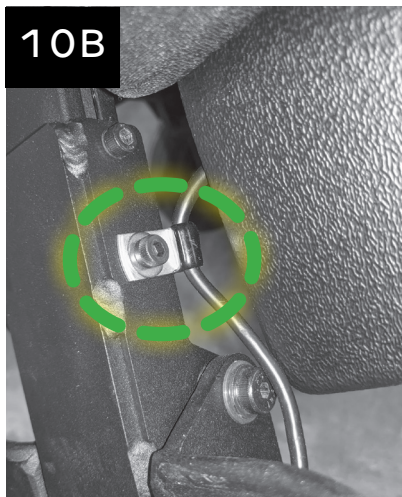
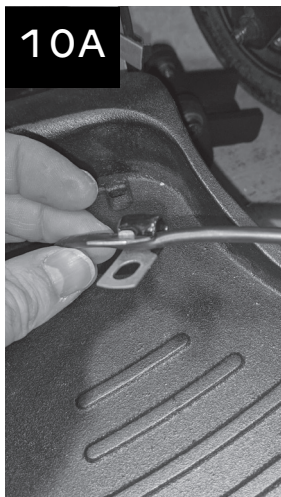

Extend the leg rest completely and route the Scout cable through the Cable Clips (AF) and carefully along a path to ensure the Scout cable does not get pinched. Route the cable along the leg rest, zip tying (AG) the cable to the frame where possible (Figures 10D and 10E).

▲ Caution: Ensure there is enough slack in the USB cable so that the seat and leg rest can move to their full extent, without causing tension on the cable. Approximately 1/2" of slack in each direction is ideal (Figure 10F).

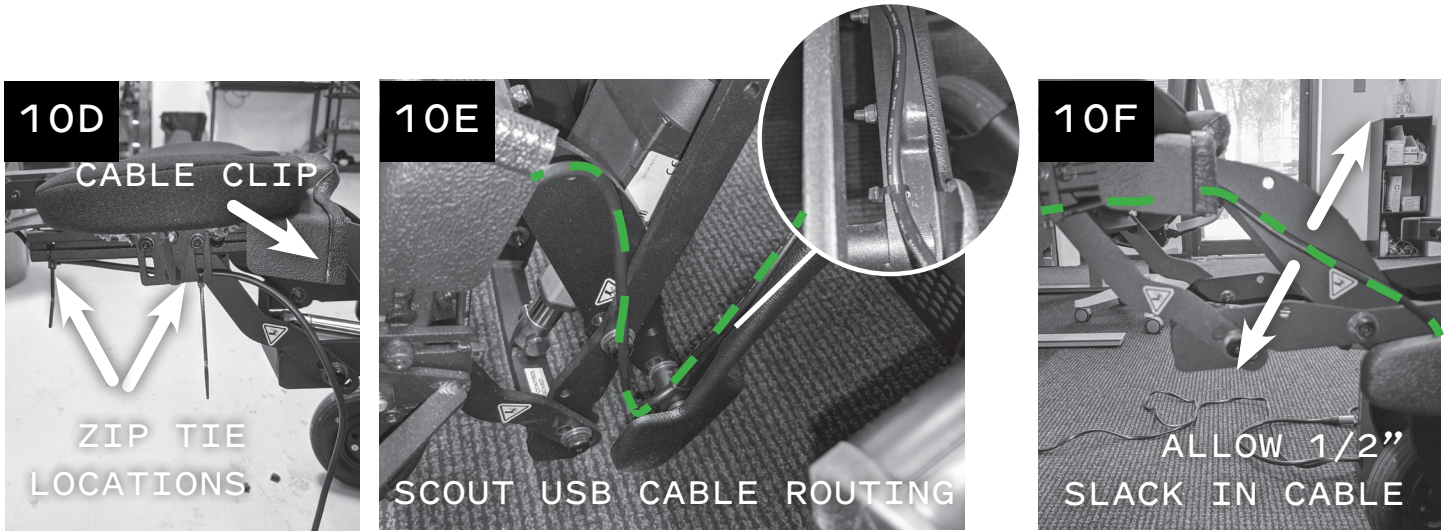

Tilt the seating assembly back and run the Scout USB cable along the side rail, zip tying (AG) it to the holes in the rail (Figure 10G). Finally, run the cable along the back left side of the seat back. Zip tie the cable to the holes in the pivot bracket (Figure 10H).

⚠ Caution: All cables should be installed, bundled and routed so as to avoid damage to the cables through pinching, dragging, etc. and to avoid excess cable length that could lead to entanglement or strangulation.

📌 Note: Check that the leg rest moves through the full range of motion without pulling or pinching the cable.

📌 Note: If the driver typically drives with the footplate raised, the Scout should be adjusted, following the instructions in Step 10B.

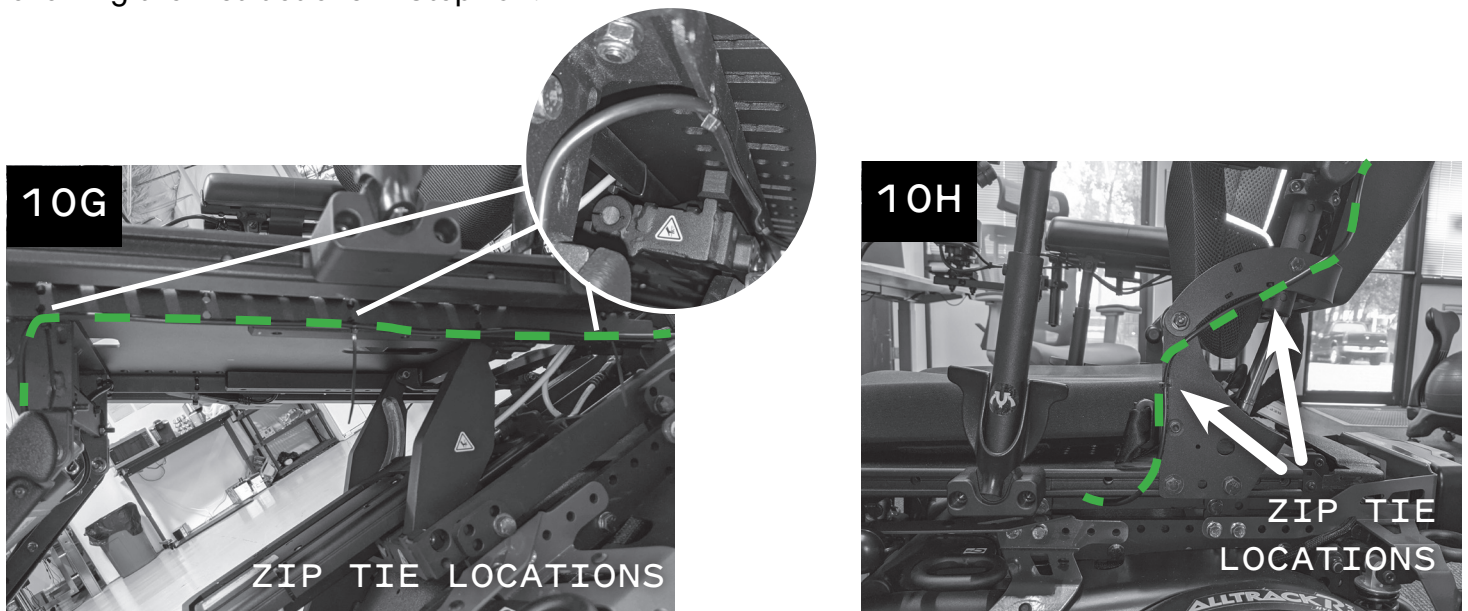

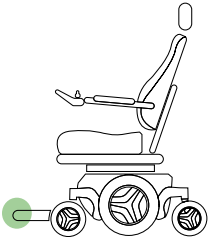

STEP 10B - ADJUSTABLE SCOUT OPTIONS

Tools Required

- Phillips P1 Screwdriver

The Scout works best when it is level with the ground or facing slightly upward. For the majority of drivers the default Scout position will work well and this step can be skipped (Figure 10B1). However, if the driver primarily drives with the footplate significantly raised or lowered, the Scout should be adjusted to an orientation that is level with the ground, to ensure proper functioning and obstacle detection.

The adjustable footplate bracket allows for variability in Scout orientation (Figure 10B2). If the driver typically drives with the footplate pointing up, the Scout can be mounted at up to 30 degrees tilt (Figure 10B3).

⚠ Caution: Do not mount the Scout facing downward, as this will cause it to see the ground as an obstacle and inhibit forward motion (Figure 10B4). Note that the Scout should be checked with the user seated, because the footplates tend to tilt downward with weight applied.

10B1



10B2

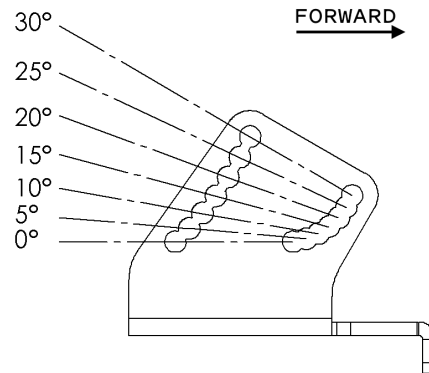

10B3



10B4

DO NOT POINT
SCOUT AT GROUND



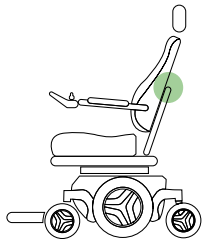

STEP 11 - ATTACH LUCILINK HUB

Tools Required

- Alcohol Wipe (AD)
- Zip Ties (AG)
- LuciLink Hub (R)
- Phillips P1 Screwdriver

Use an alcohol wipe (AD) to clean a flat area on the left side of the cover on the back of the wheelchair. Remove the Velcro backing from the LuciLink Hub (R) back cover and affix it to the cleaned area, so that the key is oriented as shown and the cable opening is at the bottom (Figure 11A). Use a Phillips P1 screwdriver to open the LuciLink Hub (R). Plug the Scout and Dashboard USB cables into the LuciLink Hub and connect the SmartFrame USB cable to the LuciLink Hub. Place the cables so that the LuciLink Hub can be closed (Figure 11B). Close the LuciLink Hub, reinsert and tighten the three screws.

i Note: The LuciLink Hub may be placed anywhere on the seat back, as long as it does not limit the range of motion of the seat, armrests, etc.

i Note: It may be easier to place the cables and close the LuciLink Hub by removing the back from the Velcro and holding the LuciLink Hub horizontally.

⚠ Caution: All cables should be installed, bundled and routed so as to avoid damage to the cables through pinching, dragging, etc. and to avoid excess cable length that could lead to entanglement or strangulation.

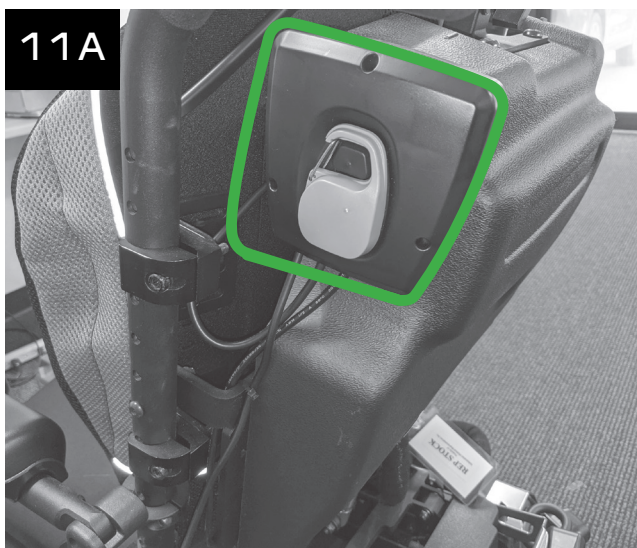

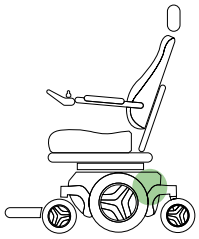

STEP 12 - INSTALL REAR COVER AND SECURE CABLES

Tools Required

- Rear Cover (Q)
- 10-32 x 3/8 Hex Head Screws (X)
- Zip Ties (AG)
- 3mm Allen Wrench
- Zip Tie Cutter

Remove the reflector or tail light from the original rear cover and transfer to the LUCI Rear Cover (Q). For wheelchairs with a tail light, unplug the tail light, feed the plug through the center hole and install the bolts. Line up the holes in the Rear Cover (Q) with the holes in the tilt frame. Insert the four 10-32 x 3/8 hex head screws (X) (two on each side) and tighten them with a 3mm Allen wrench (Figure 12A). Bundle any excess cable length and zip tie (AG) around the bundle (Figure 12B). Trim any remaining zip tie ends.

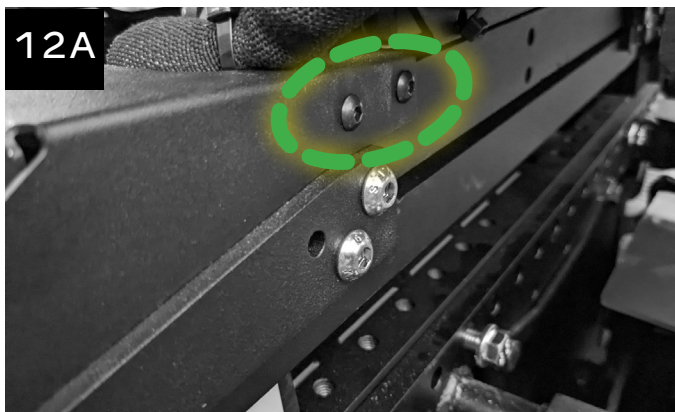

REPLACING WHEELCHAIR BATTERIES WITH LUCI INSTALLED

If you need to replace the batteries on an Amy R3 that has LUCI installed, follow these steps:

1. Use a 3mm Allen wrench to remove the six flange head screws (three on each side) that attach the Rear SmartFrame to the side rails. Gently pull the frame off the standoffs, back slightly, and then tilt it upward.
2. Swap the batteries as you normally would.
3. Lower the Rear SmartFrame into place and clip it onto the standoffs. Reinsert and tighten the six flange head screws. Ensure all cables remain neatly routed to avoid pinching or dragging.

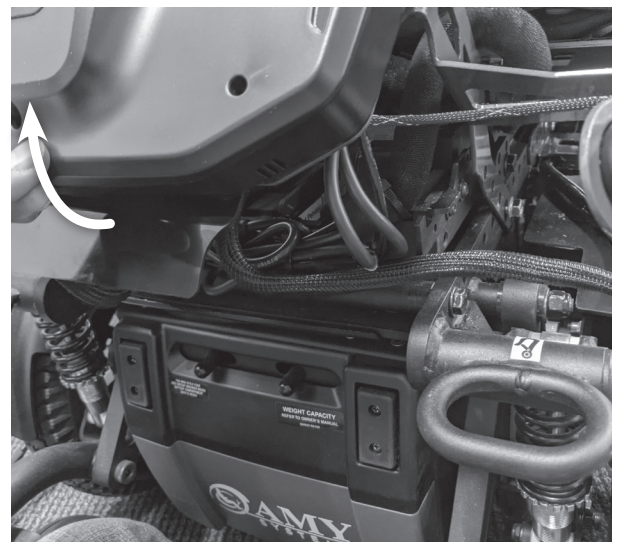

ONCE LUCI IS INSTALLED:

- Power on the wheelchair and ensure that the seat, armrests, and footrest are able to move to their full extent without pinching or pulling any cables, or compressing any parts of LUCI.
- Ensure that leg pads and accessories, such as lateral thigh supports, do not contact or block the front camera pods and/or headlights at the lowest seat elevation.
- Confirm the Dashboard Reference Card is attached to the LUCI Dashboard.
- Check that there are no loose, pinched or dragging cables.
- Confirm the Sensor Status light on the Dashboard is orange (demo mode).
- Press the LUCI button and make sure the LUCI button lights up blue, the chair can move in each direction when clear, and the chair stops in a blocked direction of travel.

Before releasing the wheelchair to the user, the system will need to be configured. With the user in the wheelchair, follow the instructions in the LUCI Quick Setup Guide.

CONGRATULATIONS,
you have installed

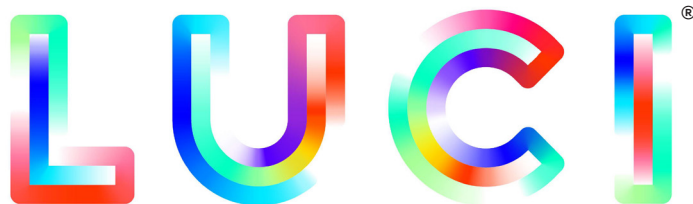
The logo for LUCI, featuring the letters L, U, C, and I in a stylized, colorful font. Each letter is composed of multiple overlapping, semi-transparent shapes in various colors (red, orange, yellow, green, blue, purple) that create a vibrant, multi-colored effect. A registered trademark symbol (®) is located to the upper right of the letter 'I'.

Copyright © 2023 LUCI, All Rights Reserved.

All product names, brands, and trademarks are property of their respective owners. All company, product, and service names used are for identification purposes only. Use of these names, trademarks, and brands does not imply endorsement.

For more information on our patents, please visit luci.com/patents

LUCI[®]

LUCI.COM

613-00024 Rev B