

INSTALLATION GUIDE  
PERMOBIL M3 / M5



# INSTALLATION GUIDE PERMOBIL M3 / M5

## PACKAGE CONTENTS

- A. LUCI SmartFrame™ (1)
- B. LuciLink™ Hub & Wheelchair Key™ (1)
- C. Scout (1)
- D. Dashboard (1)
- E. User Manual (1)
- F. Footplate Template (2)
- G. Standard (Joystick) Dashboard Bracket (1)
- H. Alternative Drive Dashboard Bracket (1)
- I. 3/16 Inch Drill Bit (1)
- J. Alcohol Wipe (1)
- K. Thumbscrew (2)
- L. M8 Hex Bolt (2)
- M. M4 Screw (3)
- N. M5 Allen Head Screw (2)
- O. ¼ Inch Screw (4)
- P. Zip Ties (12 short, 6 long)
- Q. Dashboard Reference Card (2)
- R. (Optional) Headlight Kit & Instructions (1)

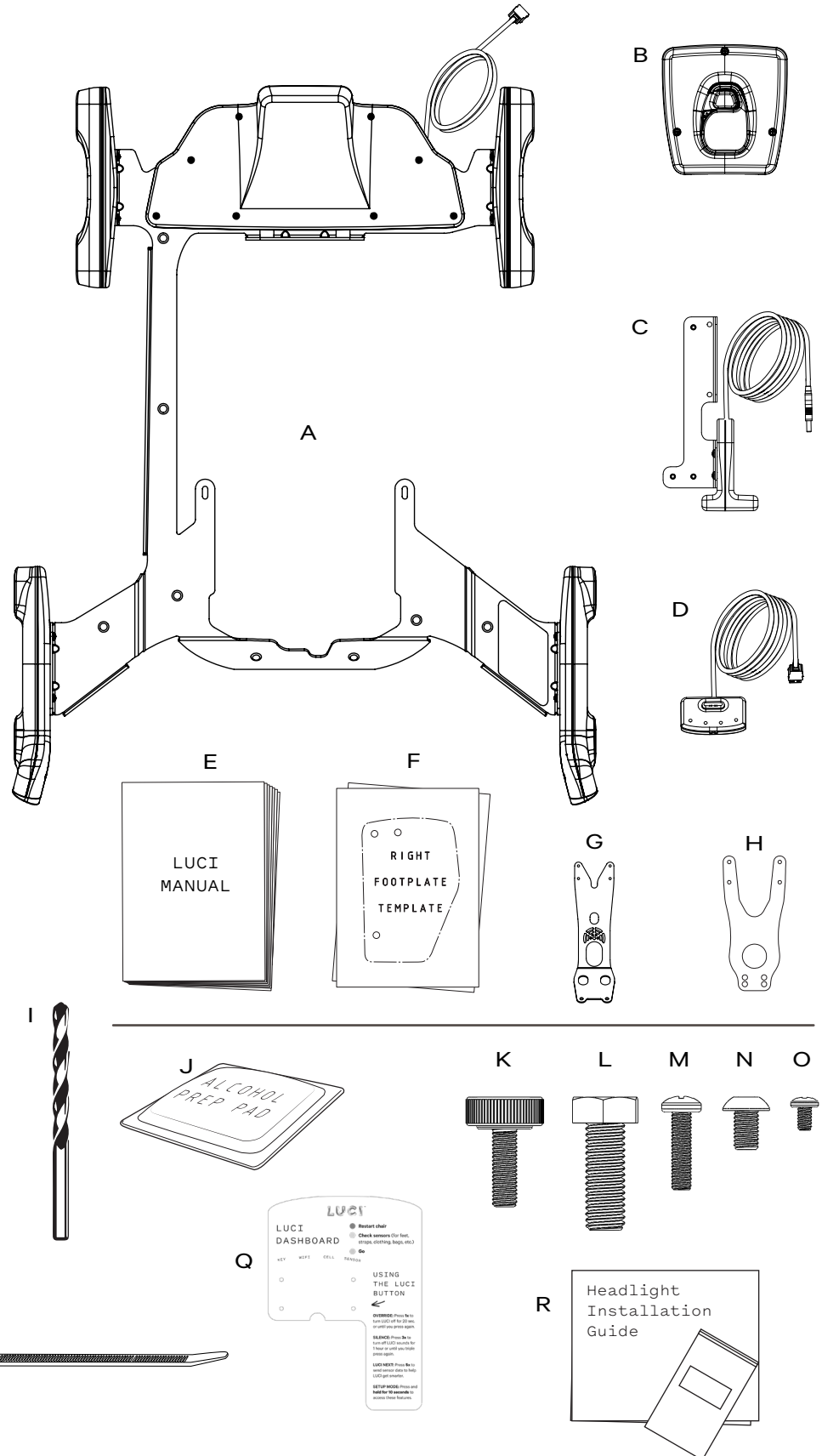

NOTE: You will also need:

- 3mm Allen Wrench
- 6mm Allen Wrench
- 13mm Wrench
- Phillips P1 Screwdriver
- Power Drill
- Adhesive Tape
- Brush & Dustpan or Vacuum

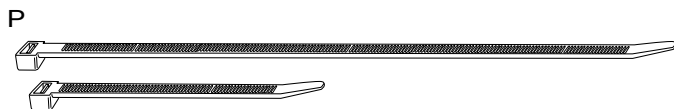

# INSTRUCTIONS

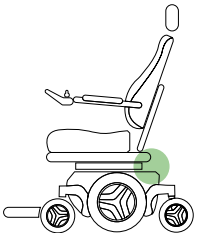

## STEP 1 - PREPARE WHEELCHAIR BASE

### Tools Required

- 6mm Allen Wrench
- M8 Hex Bolts (L)

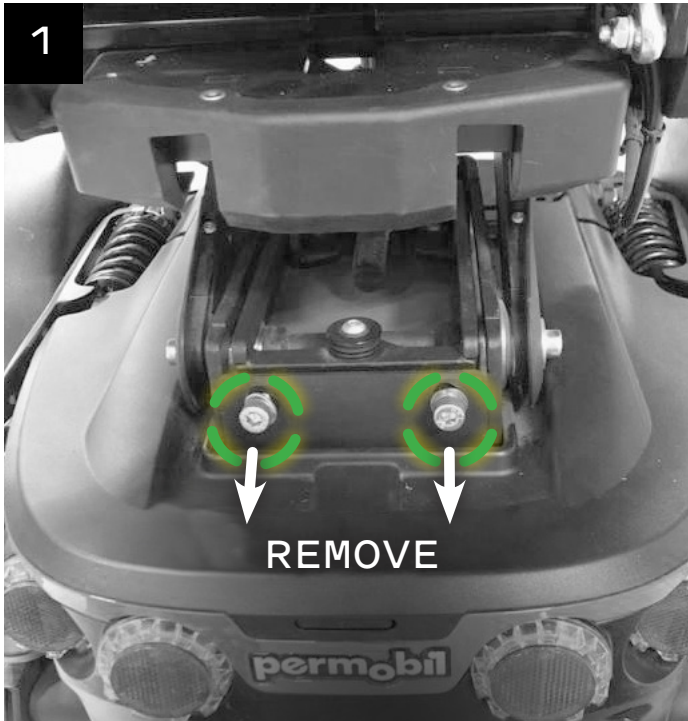

Using a 6mm Allen wrench, remove one of the two bolts on the back of the wheelchair (Figure 1) and set it aside.

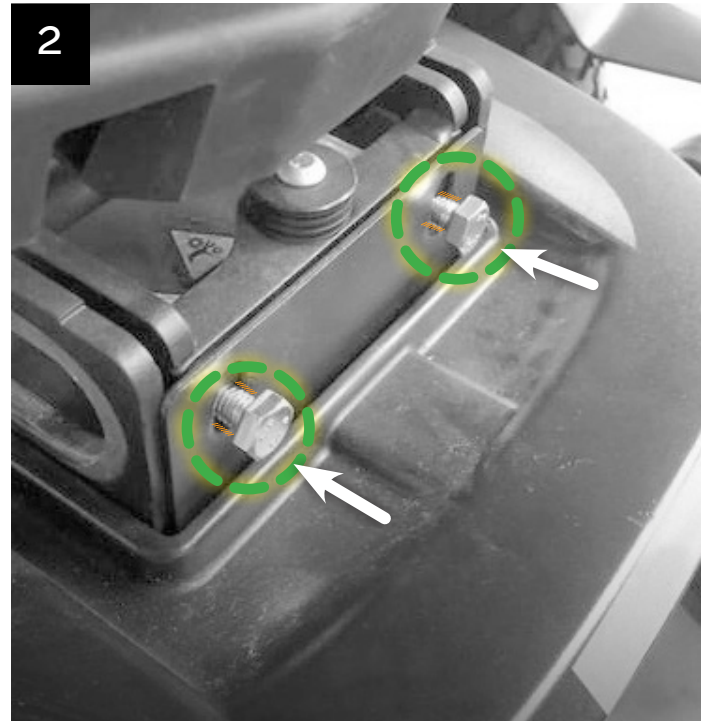

In its place, insert an M8 hex bolt (L) and hand tighten, leaving about ¼ inch spacing (Figure 2). Repeat with the other bolt.

**⚠ Caution:** Do not overtighten!

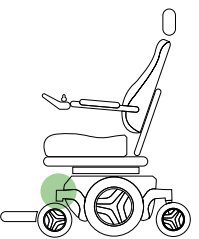

## STEP 1 (B) - HEADLIGHT REMOVAL

### Tools Required

- (Optional) Headlight Kit and Instructions (R)

If the wheelchair has headlights, use the Headlight Kit and follow the included instructions to remove them now. Note that the final step of the headlight instruction booklet will be done after Step 6.

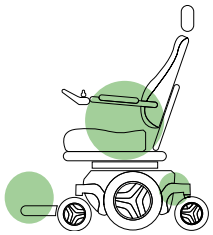

## STEP 2 - MAKE ROOM FOR INSTALLATION

No Tools Required



Power the wheelchair on and raise the chair seat and legs to gain appropriate access (Figure 3). For models with a raising seat, raise the seat out of the way. Power the wheelchair off and turn off the main breaker on the back of the chair.

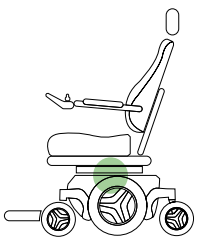

## STEP 3 - REMOVE WHEELCHAIR BATTERY COVER

No Tools Required

Remove the two thumbscrews underneath the seat on the wheelchair base and set them aside (Figure 4). Ensure the back wheels of the wheelchair are straight. Slide existing rear top cover back a few inches and remove the rear battery cover.

**i** Note: If thumbscrews are too tight, use a 4mm Allen wrench to loosen them.

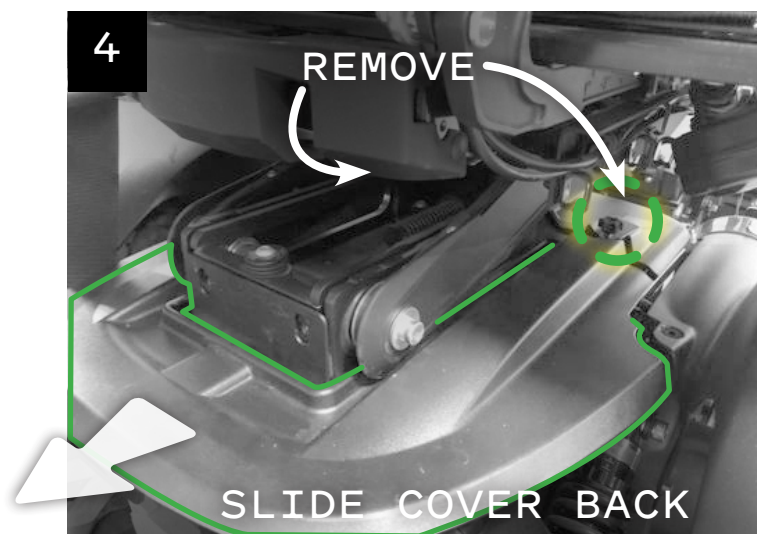

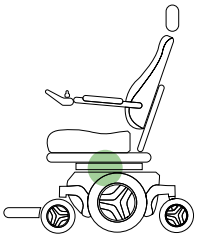

## STEP 4 - PLACE LUCI SMARTFRAME

### Tools Required

- LUCI SmartFrame (A)

Hook the LUCI SmartFrame (A) around the seat mechanism beginning at the front and rotating 90° clockwise (Figure 5). Slot the LUCI SmartFrame down onto the bolts on the back of the wheelchair. Ensure that the LUCI SmartFrame is lying flat on the wheelchair base and is not pinching any existing cables or hardware (Figures 6 and 7).

### 5 ROTATE INTO PLACE

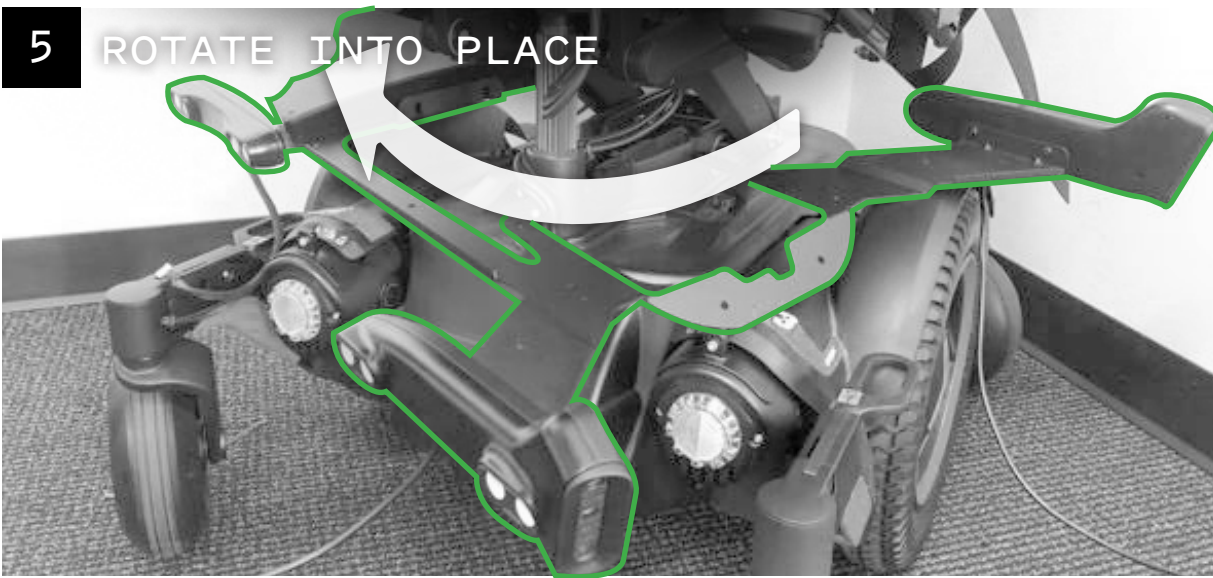

### 6 HOOKED CABLE

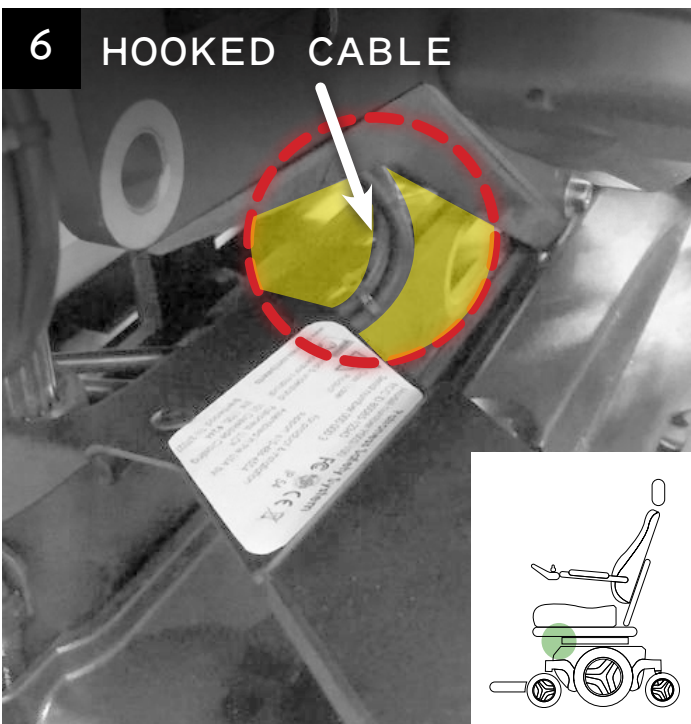

### 7 PINCHED HARDWARE

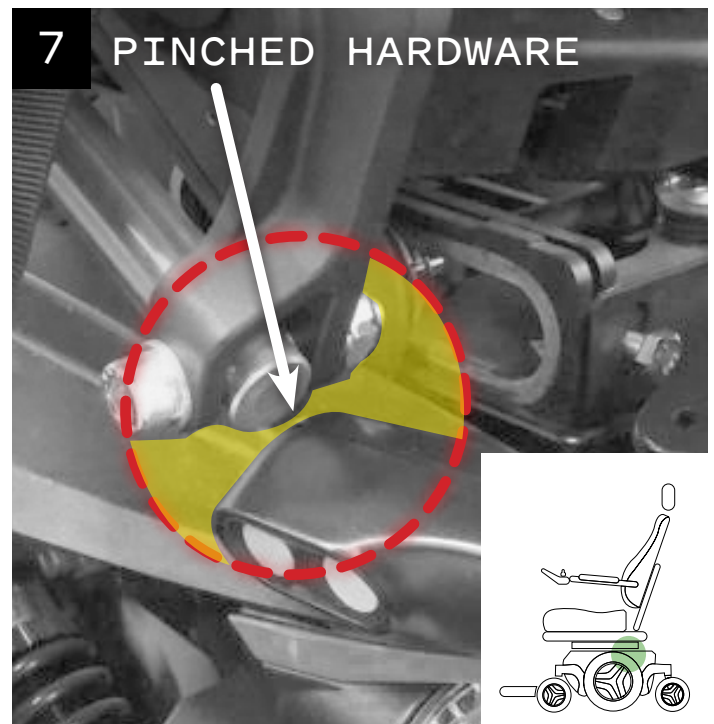

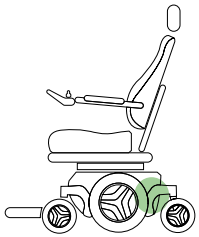

## STEP 5 - CONNECT LUCI TO WHEELCHAIR

No Tools Required

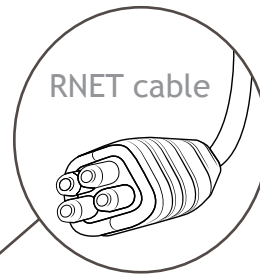

On the back of the wheelchair, unplug the main RNET cable on the far left (Figure 8) and plug it into the female RNET cable end on LUCI. Plug the male RNET cable end from LUCI into the main wheelchair RNET outlet on the far left (Figure 9). Turn the breaker and wheelchair on to ensure all power cables have been properly connected. Turn off the wheelchair. Replace the back battery cover and close the rear compartment.

- ⚠ Caution: Do not plug the RNET cable into any other openings (even if they seem more convenient).
- ⚠ Caution: Ensure that the main wheelchair breaker is flipped on.
- ⚠ Caution: Ensure that the covers are aligned.

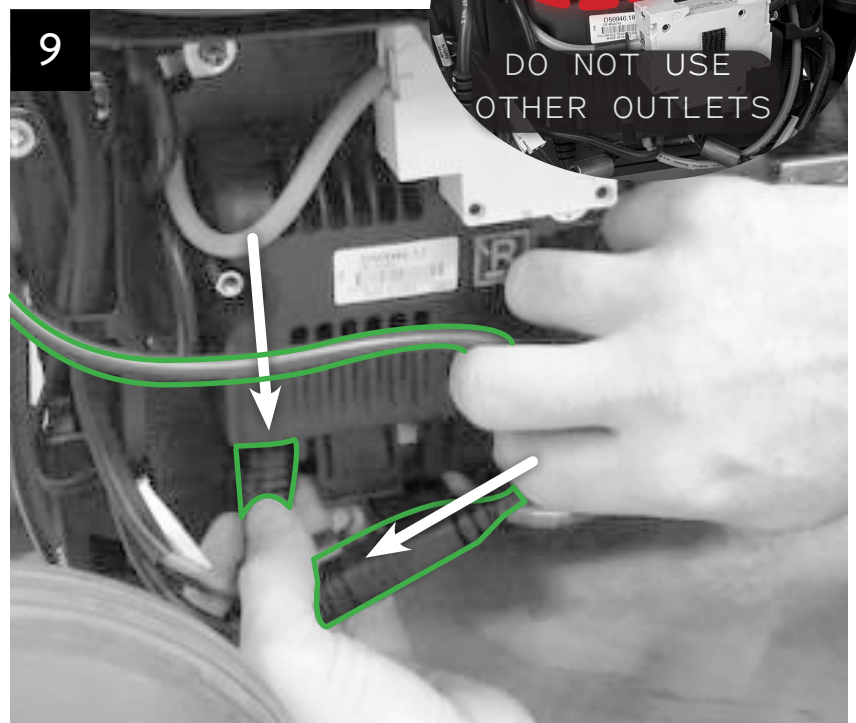
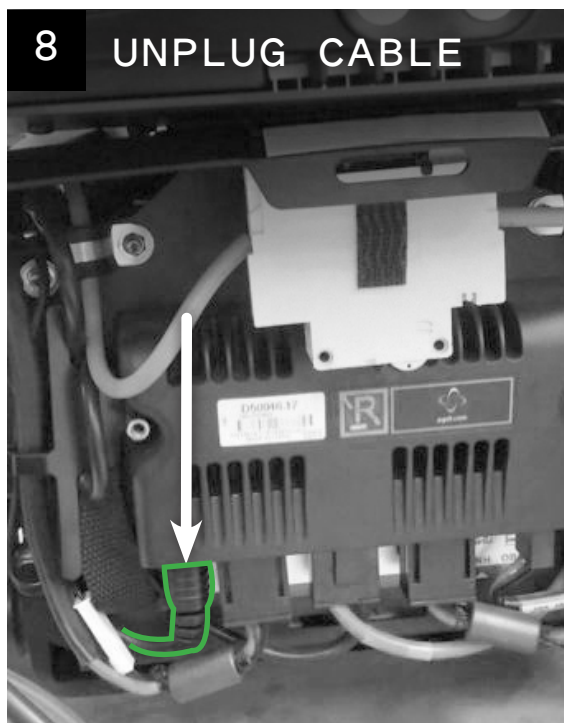
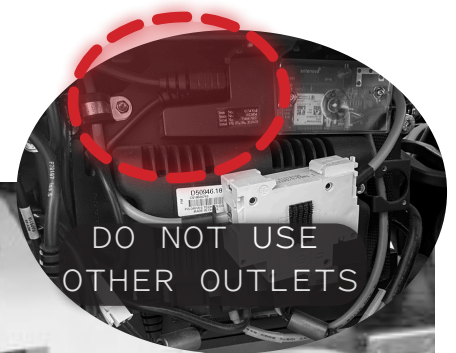

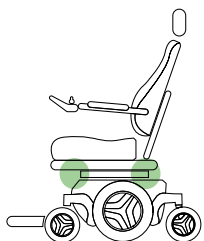

## STEP 6 - SECURE THE SMARTFRAME

### Tools Required

- 13mm Wrench
- Thumbscrews (K)

Insert and tighten the two thumbscrews (K) on the front of the chair (Figure 10). Tighten the two hex bolts on the back of the chair with a 13mm wrench (Figure 11).

**i** Note: If necessary, the SmartFrame can be bent slightly to better align the thumbscrew holes.

**▲** Caution: Ensure that the SmartFrame USB cable loop is routed on top of the LUCI unit.

**▲** Caution: Ensure that the front camera FusionSensors on the front of the unit are level.

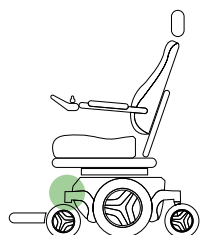
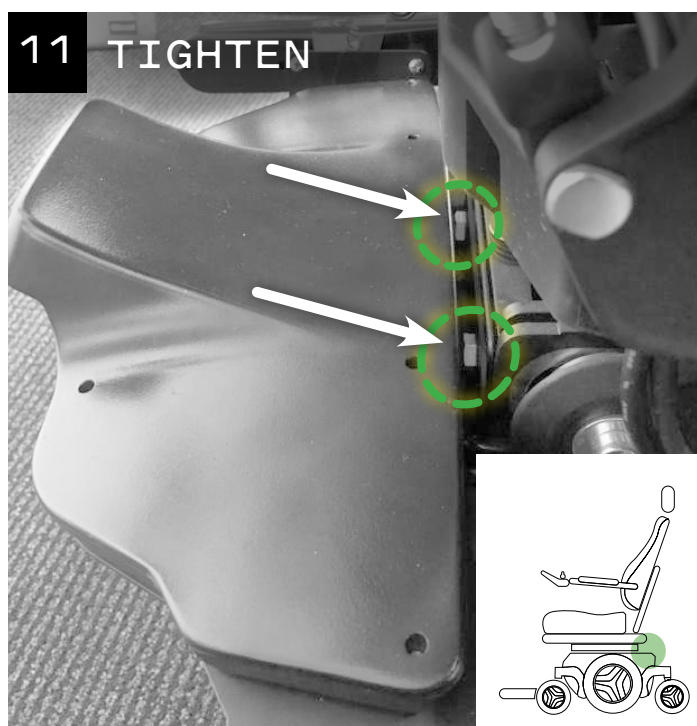
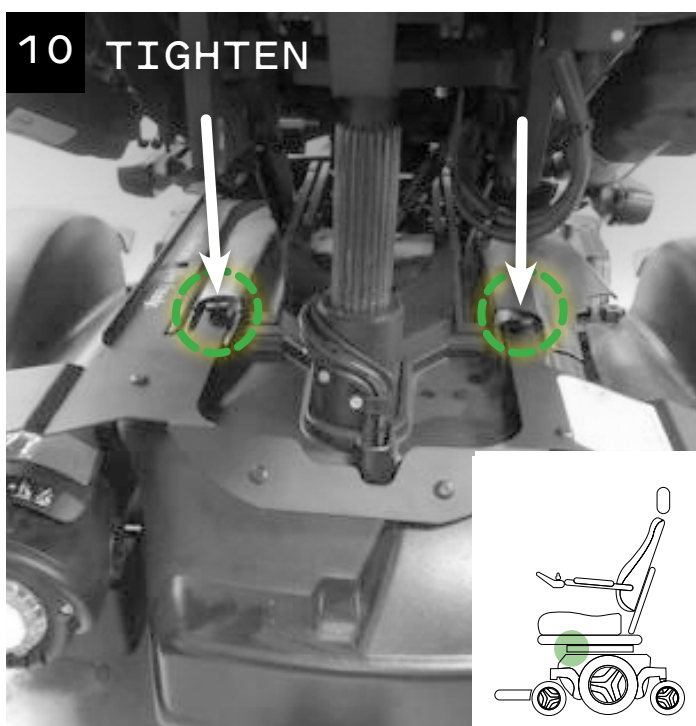

## STEP 6 (B) - MOUNT HEADLIGHTS

### Tools Required

- (Optional) Headlight Kit and Instructions (R)

If the wheelchair has headlights, finish the final step of the Headlight Installation guide to insert the bracket between the SmartFrame and front FusionSensor pod.

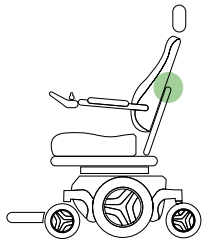

## STEP 7 - ATTACH LUCILINK HUB

### Tools Required

- Alcohol Wipe (J)
- Zip Ties (Short) (P)

Use the alcohol wipe (J) to clean a flat area on the wheelchair seat back. Remove the Velcro backing from the LuciLink Hub (B) back cover and affix it to the cleaned area, so that the key is oriented as shown and the cable opening is at the bottom (Figure 12). Route the SmartFrame USB cable toward the LuciLink Hub, along existing cabling, zip tying it in place.

**i** Note: If the wheelchair seat raises and lowers, raise the seat to its fullest extent and follow existing cabling along the seat mechanism, zip tying it in place as needed. (Figures 13 and 14).

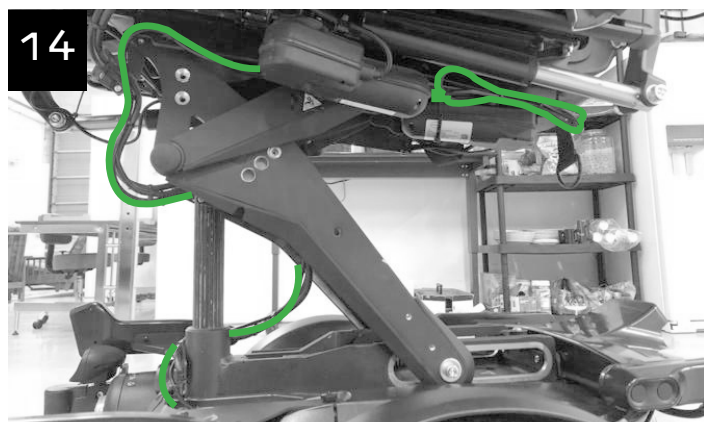
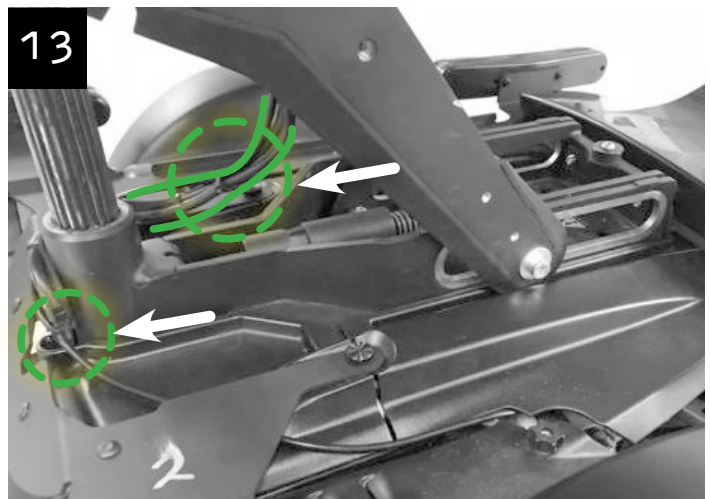
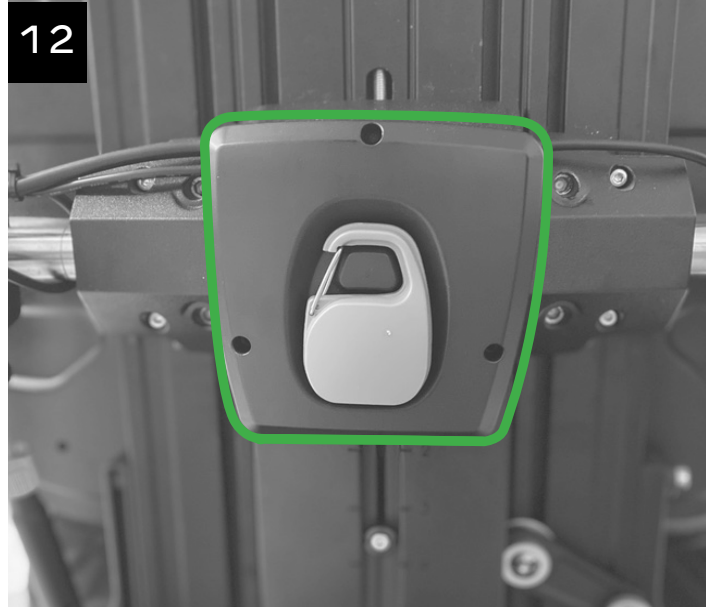

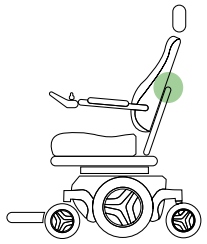

## STEP 8 - SECURE CABLING

### Tools Required

- Zip Ties (Short)(P)
- Phillips P1 Screwdriver

Remove the front cover of the LuciLink Hub (B) using the Phillips P1 screwdriver, to expose the USB outlets inside (Figure 15). Plug the SmartFrame USB cable into the LuciLink Hub. If the cable is too long (specifically for models with seats that do not raise), loop the excess cable and zip tie it together, securing it to the wheelchair.

**⚠ Caution:** All cables should be installed, bundled and routed so as to avoid damage to the cables through pinching, dragging, etc. and to avoid excess cable length that could lead to entanglement or strangulation.

**⚠ Caution:** If the driver typically uses backpacks or hangs other bags off his/her wheelchair, suggest the user clip the Wheelchair Key to a different location on the wheelchair to avoid knocking it out of its magnetized place on the LuciLink Hub (B).

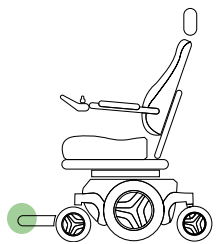

## STEP 9 - PREPARE THE FOOTPLATE

### Tools Required

- Adhesive Tape
- Footplate Template (F)
- Phillips Screwdriver
- Drill
- 3/16 Inch Drill Bit (I)
- Brush and Dustpan OR Vacuum

Lower the foot rest completely. Align the correct footplate (standard or wide) template (F) on the right footplate (Figure 16) and tape it in place so that it does not shift. Use a Phillips screwdriver to make pilot hole marks in the footplate template to help with drilling the holes in the correct location. Insert the drill bit (I) into your drill and drill the three holes. Ensure the holes on the footplate bracket line up with the holes you drilled.

**i Note:** For extra wide footplates, use the wide footplate template, aligning it in the inside, forward corner of the footplate.

**⚠ Caution:** Use a brush or vacuum to get rid of the metal shavings as these are sharp!



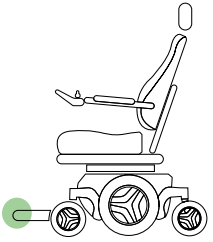

## STEP 10 - ATTACH SCOUT

### Tools Required

- M4 Screws (M)
- Zip Ties (Short) (P)
- Zip Tie (Long) (P)
- Phillips P1 Screwdriver
- Scout (C)

Use three M4 screws (M) to screw the Scout (C) to the underside of the footplate (Figure 17).

Route the Scout cable along the side and top of the footplate as shown (Figure 18), then along the back of the leg rest, using short zip ties to tie it to the stationary bracket low on the leg rest (Figure 19).

Raise the foot rest to its fullest extent (Figure 20) and use the long zip tie (P) to secure the cable to the stationary bracket just under the seat (Figure 21).

From there, follow existing cabling underneath the seat, utilizing the existing cable clips (Figure 22), toward the back of the seat to the LuciLink Hub (B) on the back of the chair.

**⚠ Caution:** Do not route the cable below the footplate, as this may cause damage to the cable.

**⚠ Caution:** Ensure there is enough slack in the USB cable so that the seat and foot rest can move to their full extent, without dragging the cable.

**⚠ Caution:** Ensure that the full extent of the cable is secured with zip ties and cable clips where possible. If necessary, foot straps may be screwed in through the footplate bracket after installation.

**⚠ Caution:** All cables should be installed, bundled and routed so as to avoid damage to the cables through pinching, dragging, etc. and to avoid excess cable length that could lead to entanglement or strangulation.

**📌 Note:** If the driver typically drives with the footplate raised, the Scout should be adjusted to an orientation that is level with the ground, to ensure proper functioning and obstacle detection. Refer to Step 10 (B) for adjustment information.

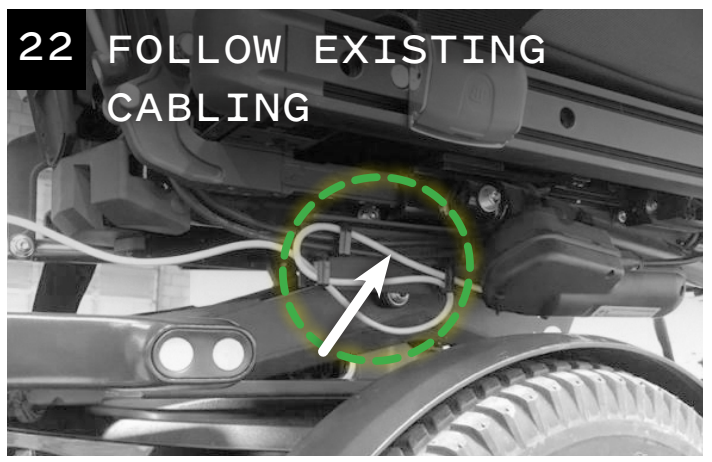
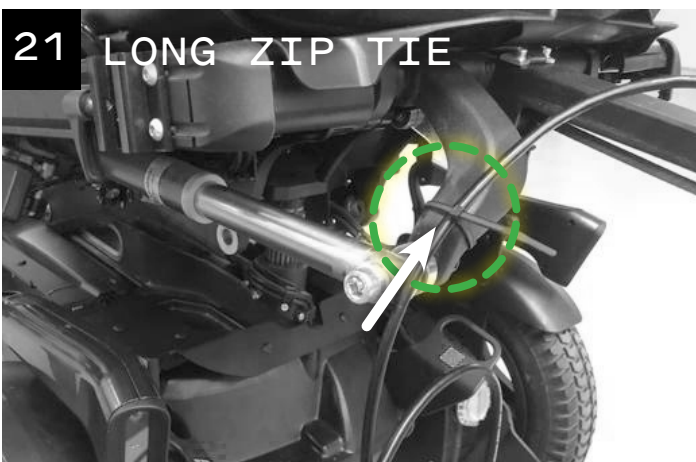
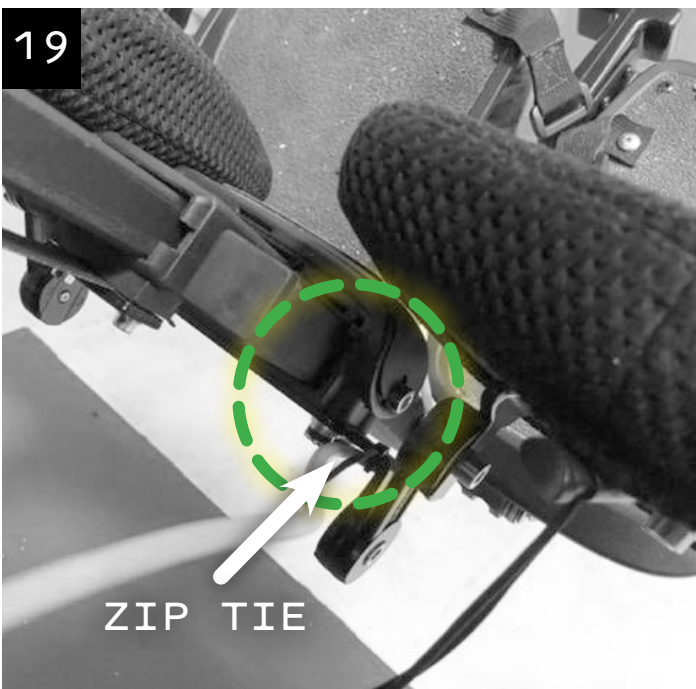
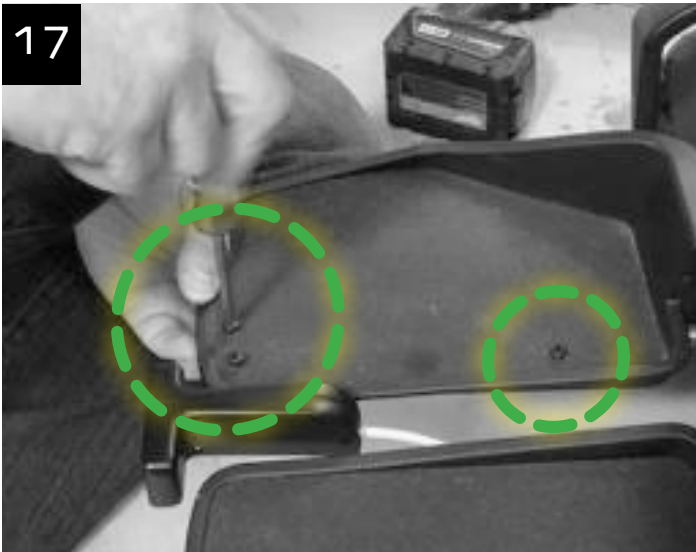

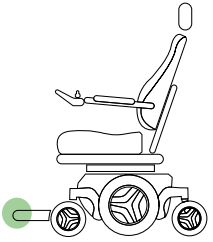

## STEP 10 (B) - ADJUSTABLE SCOUT OPTIONS

### Tools Required

- Phillips P1 Screwdriver

The Scout works best when it is mounted level with the ground, or facing slightly upward. For drivers who drive with their footplate in the standard position, the default position of the Scout will work well and this step can be skipped (Figure 23 A). However, if the driver typically drives with the footplate raised or lowered, the Scout should be adjusted to an orientation that is level with the ground, to ensure proper functioning and obstacle detection.

The adjustable footplate bracket allows for significant variability in Scout orientation (Figure 23 B). If the driver typically drives with the footplate up, the Scout can be mounted at up to -50 degrees (Figure 23 C). If the driver typically drives with the footplate lowered, the Scout can be mounted at up to 15 degrees (Figure 23 D). If the driver has a one piece footplate, the Scout bracket can also be mounted upside-down near the center of the footplate. Note that the Scout itself should still be mounted in the standard orientation (Figure 23 E).

**⚠ Caution:** Do not mount the Scout facing downward, as this will cause it to see the ground as an obstacle and inhibit forward motion (Figure 23 F).

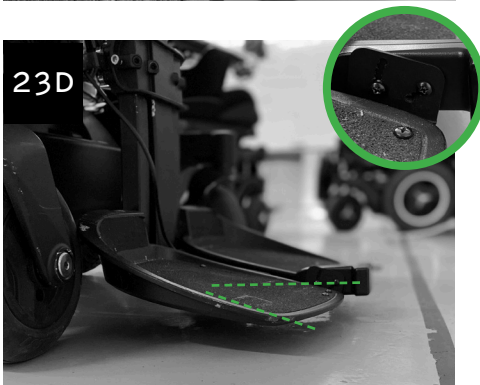
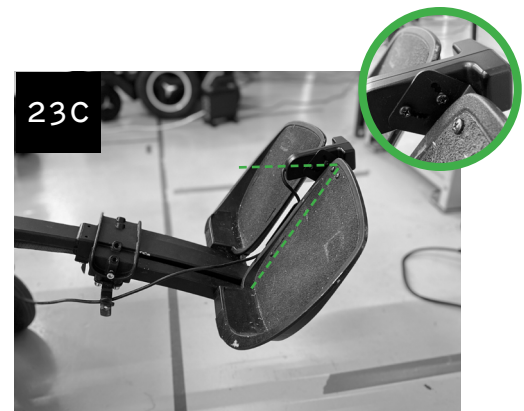
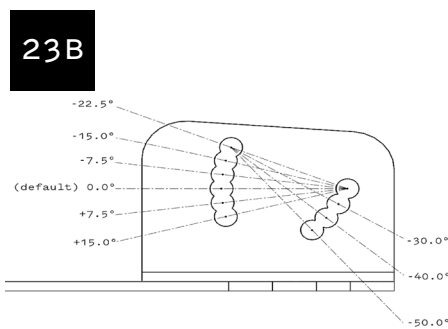

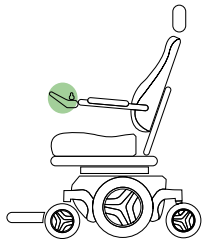

## STEP 11 - INSTALL THE DASHBOARD

### Tools Required

- |   |                                |
|---|--------------------------------|
| - Size 3 Allen Wrench                       | - Dashboard (F)                |
| - Standard (Joystick) Dashboard Bracket (G) | - ½ Inch Screws (N)            |
| - Alternative Drive Dashboard Bracket (H)   | - ¼ Inch Screws (O)            |
|   | - Zip Ties (Short) (P)         |
|   | - Dashboard Reference Card (Q) |

Choose the correct Dashboard bracket based on the wheelchair drive system: (G) for standard joystick or (H) for alternative drive. Choose the correct (left or right) Dashboard Reference Card (Q). Use four ¼ inch screws (O) to attach the bracket to the back of the Dashboard (D), sandwiching the Dashboard Reference Card (Q) between them and ensuring the cable is routed correctly (Figure 24 - A, B or C). Note that for newer wheelchairs, the joystick module is taller, so the Dashboard should only be attached to the top two holes on the bracket; insert screws into the top two holes on the Dashboard to ensure the unit stays sealed (Figure 24 B).

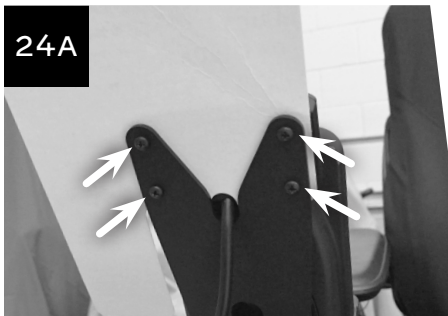

Use a size 3 Allen wrench to remove the joystick module. Insert the Dashboard bracket between the armrest and the joystick module and reinsert the screws (Figure 25 - A or B). Note that newer Omni modules are taller and will require use of the lower screw holes, as well as longer screws (N). Follow existing cabling (Figure 26) to route the cable to the LuciLink Hub (B) and use zip ties (P) to attach cables along the way.

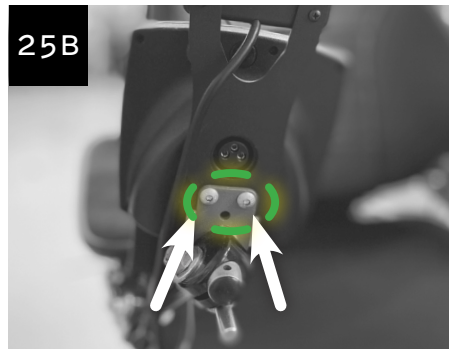

**i** Note: For alternative drive wheelchairs, the Dashboard (D) includes an auxiliary jack. Any momentary switch plugged into the jack can be used as the override button. If not used, be sure to keep the dust plug in the jack.

**⚠** Caution: All cables should be installed, bundled and routed so as to avoid damage to the cables through pinching, dragging, etc. and to avoid excess cable length that could lead to entanglement or strangulation.

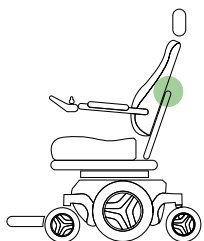

## STEP 12 - PLUG IN USB CABLES

### Tools Required

- Phillips P1 Screwdriver

Plug the Scout (C) and Dashboard (D) USB cables into the USB outlets (Figure 27). Ensure all USB cables are securely seated inside the LuciLink Hub and do not interfere with screw holes (Figure 28). Reattach the front cover of the LuciLink Hub (Figure 29).

**⚠ Caution:** Clip all the zip ties to remove any dangling ends.

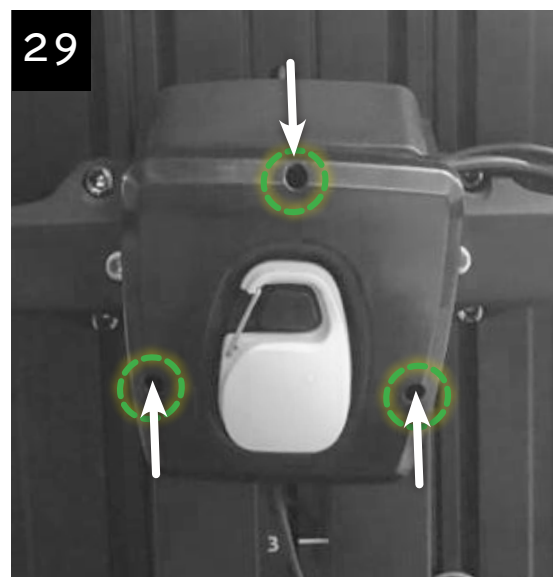
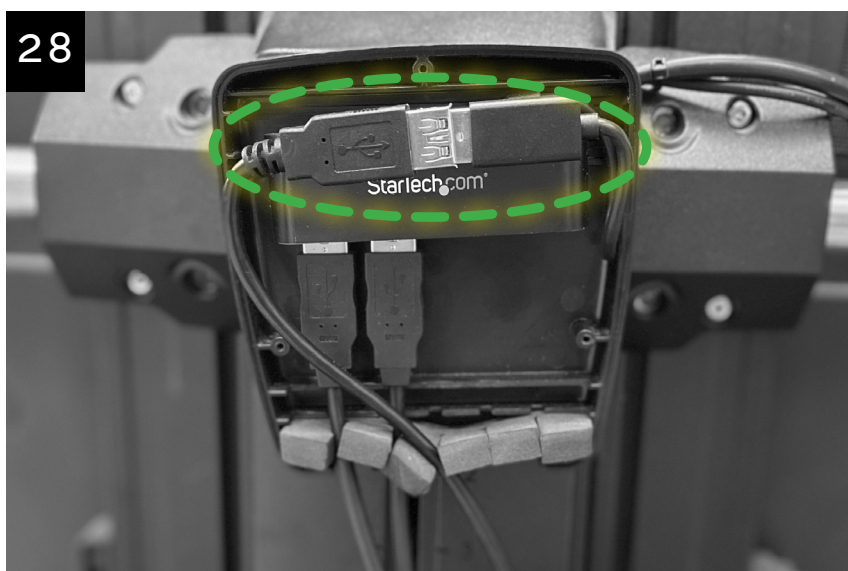
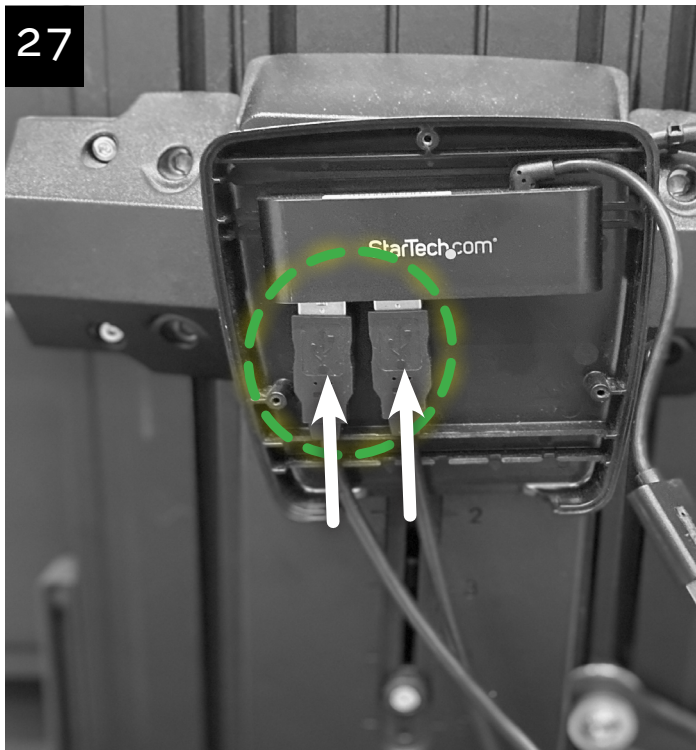

**i** Note: Power on the wheelchair and ensure that the seat and footrest are able to move to their full extent without pinching or pulling any cables.

Before releasing the wheelchair to the user, the system will need to be configured. With the user in the wheelchair, follow the instructions in the LUCI Quick Start Guide.

CONGRATULATIONS,  
you have installed

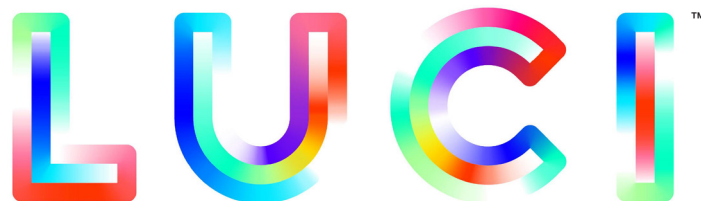

Copyright © 2020 LUCI, All Rights Reserved.

P002-011 v3.0

All product names, brands, and trademarks are property of their respective owners. All company, product, and service names used are for identification purposes only. Use of these names, trademarks, and brands does not imply endorsement.

For more information on our patents, please visit [luci.com/patents](https://luci.com/patents)

LUCI™

LUCI.COM