

INSTALLATION GUIDE
QUICKIE Q300 M



INSTALLATION GUIDE

QUICKIE Q300 M

PACKAGE CONTENTS

- A. Rear SmartFrame™ (1)
- B. Left SmartFrame™ (1)
- C. Right SmartFrame™ (1)
- D. Scout (1)
- E. Footplate Drill Guides (2)
- F. Dashboard (1)
- G. Dashboard Reference Card (2)
- *Bracket based on order form:*
 - H. LED Joystick Dashboard Bracket (1)
 - I. Color Joystick Dashboard Bracket (1)
 - J. Color Joystick Spacer (1)
 - K. CJSM 1/2 Dashboard Bracket (1)
 - L. OMNI Dashboard Bracket (1)
- M. Head/Tail Light Hardware Kit (1)
- N. Alcohol Wipe (2)
- O. LuciLink™ Hub & Wheelchair Key™ (1)
- P. 1/4" Drill Bit (1)
- Q. 5/16" Drill Bit (1)
- R. M8 x 22mm Socket Head Screw (4)
- S. M8 x 16mm Low Profile Socket Cap Screw (4)
- T. M5 x 16mm Hex Head Screw (2)
- U. M5 x 14mm Phillips Head Screw (1)
- V. M5 x 8mm Hex Head Screw (2)
- W. M5 x 8mm Phillips Head Screw (3)
- X. 4-40 x 3/16 Philips Head Screw (4)
- Y. M8 Nylon Insert Locknut (4)
- Z. M5 Nylon Insert Locknut (1)
- AA. #10 Washer (2)
- AB. Zip Ties (18 short, 8 long)
- AC. Cable Clips (12)
- AD. User Manual (1)

You will also need:

- 3mm Allen Wrench
- 5mm Allen Wrench
- 13mm Wrench
- 8mm Socket Wrench
- Phillips P1 Screwdriver
- Masking Tape
- Drill
- Zip Tie Cutter

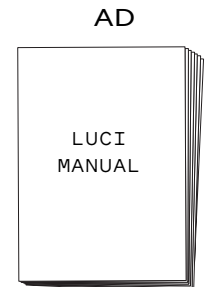
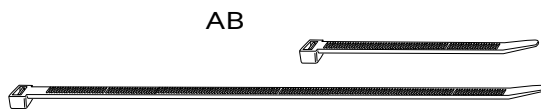
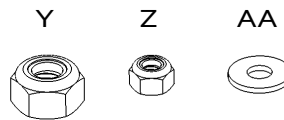
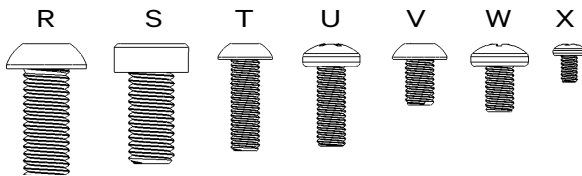
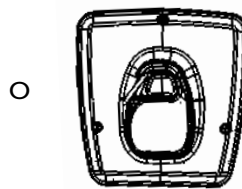
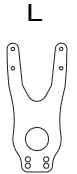
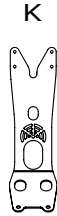
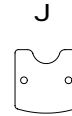
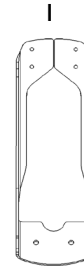
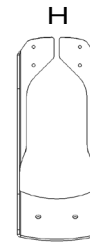
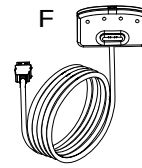
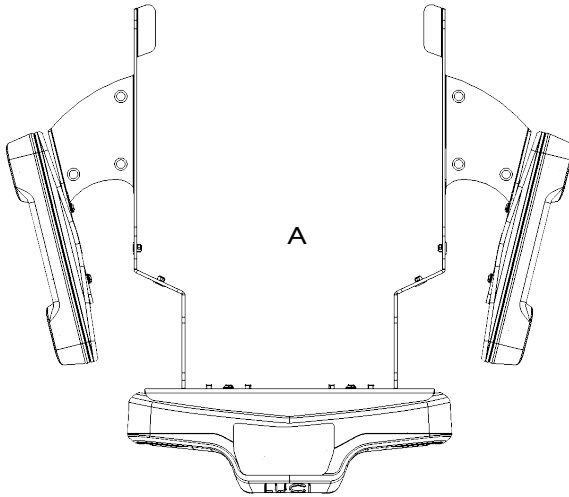
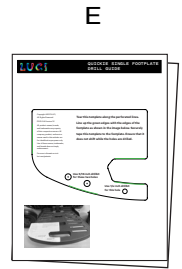
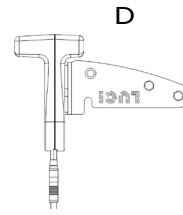
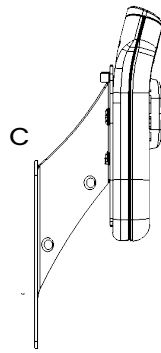
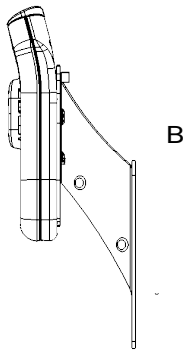

INSTRUCTIONS

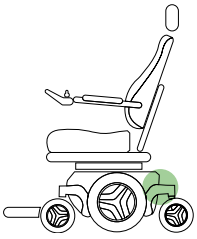

STEP 1 - PREPARE WHEELCHAIR BASE

Tools Required

- Rear SmartFrame (A)
- Left SmartFrame (B)
- Right SmartFrame (C)
- 5mm Allen Wrench

Place the Rear, Left and Right SmartFrames (A, B and C) on the floor around the wheelchair (Figure 1). Remove the screws from the railing on the back of the chair on both sides with a 5mm allen wrench (Figure 2).

i Note: If the wheelchair has tail lights, remove them to make room; these will be reattached at a later step.

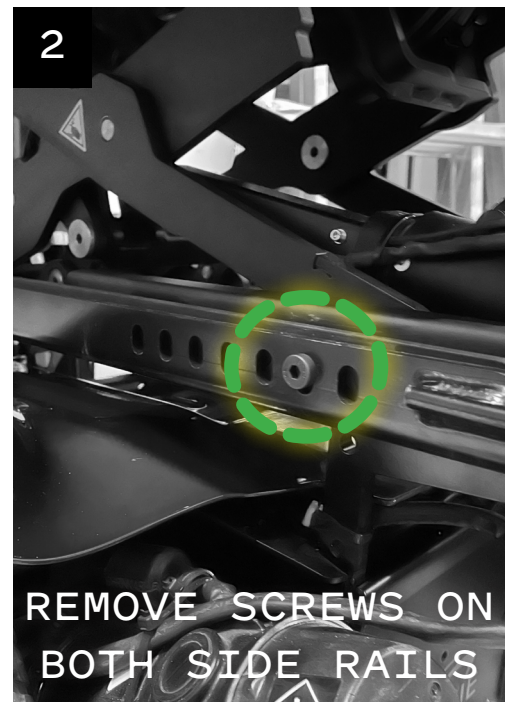
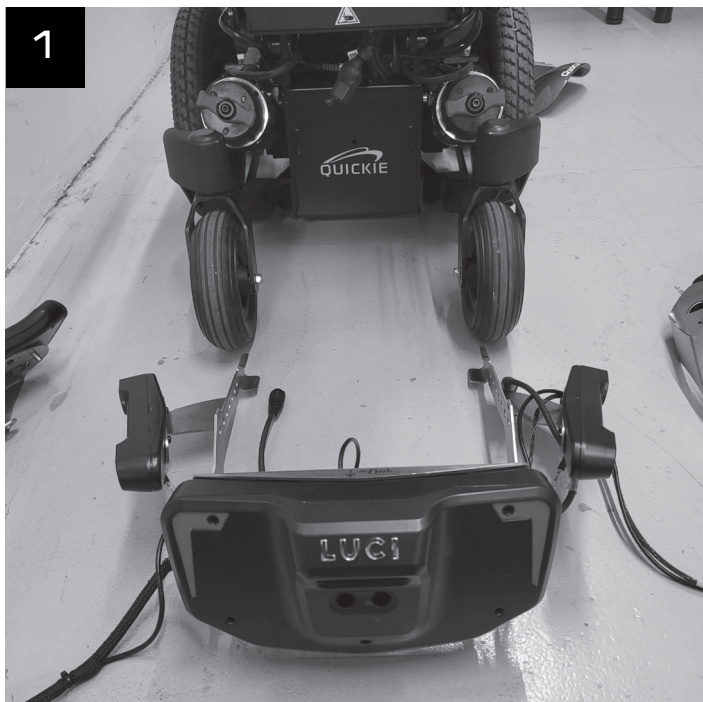

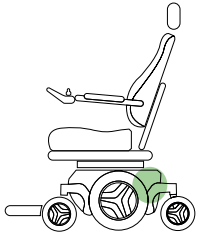

STEP 2 - SECURE REAR SMARTFRAME

Tools Required

- Rear SmartFrame™ (A)
- M8 × 16mm Low Profile Screw (S)
- 5mm Allen Wrench
- Head/Tail Light Hardware Kit (M)

i Note: If the wheelchair has a seat elevator, raising the seat now will make installation easier.

Slide the Rear SmartFrame (A) under the tie downs and up into place. Hold it so that the second to last hole aligns with the threaded hole that attaches the seating assembly to the chair (Figure 3). Insert one M8 x 16mm Low Profile Socket Cap Screw (S) on each side to secure the Rear SmartFrame to the wheelchair (Figure 4).

i Note: Check that the bubble is centered to ensure the SmartFrame is mounted level (Figure 4). Tighten the screw; The manufacturer recommends 25 N-m (18 ft-lb) of torque on these fasteners. Remove the bubble level once the SmartFrame is level and secured.

If the wheelchair has tail lights, use the contents of the Head/Tail Light Hardware Kit (M) to attach them to the Rear SmartFrame. Slide a rubber washer onto the threaded stud below the back plastic housing. Insert an M4 x 30mm screw into the tail light and attach the tail light to the SmartFrame (Figure 5). Repeat on the other side.

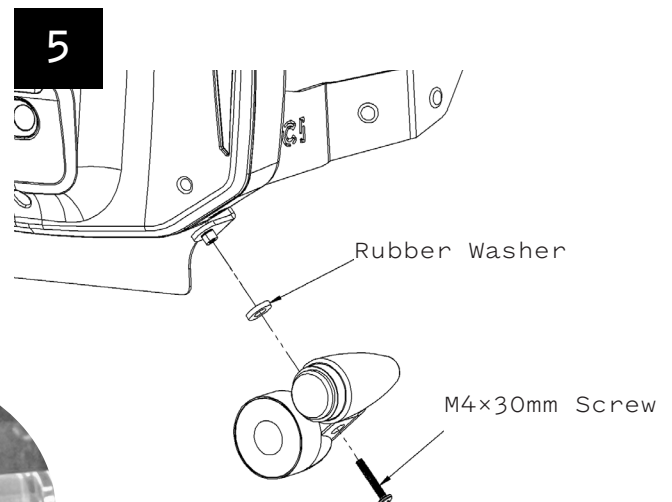

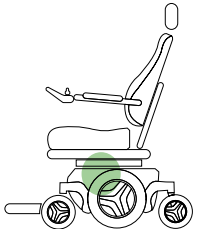

STEP 3 - CONNECT LUCI TO THE WHEELCHAIR

No Tools Required

Remove the thumbscrews attaching the seating assembly to the front seat posts and tilt the seating assembly back to gain access to the base of the chair (Figure 6).

▲ Caution: Use the kickstand and **do not go past the kickstand travel** to avoid damaging the Rear SmartFrame (Figure 7).

Remove the plastic cover to gain access to the R-NET cables (Figure 7). Unplug the main R-NET cable (Figure 8) and plug it into the female R-NET cable end on LUCI. Plug the male R-NET cable end from LUCI into the main wheelchair R-NET outlet (Figure 9). Close the battery compartment and reinsert the thumbscrews. Turn the wheelchair on to ensure all power cables have been properly connected. Turn off the wheelchair.

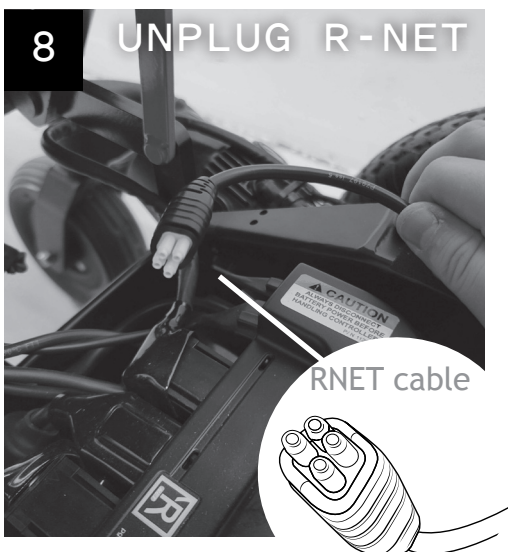
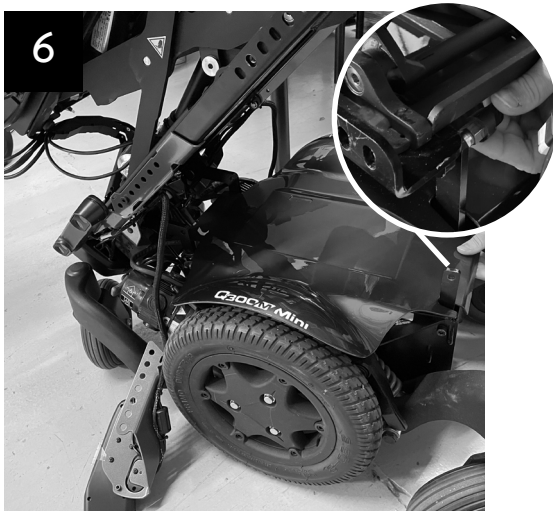

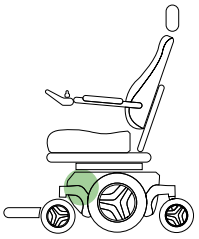

STEP 4 - SECURE SIDE SMARTFRAMES

Tools Required

- Left SmartFrame (B)
- Right SmartFrame (C)
- M8 × 22mm Screw (R)
- M8 × 16mm Screw (S)
- M8 Nylon Locknut (Y)
- Head/Tail Light Hardware Kit (M)
- 5mm Allen Wrench
- 13mm Wrench

i Note: If the wheelchair has headlights, remove them to make room; these will be reattached once the Side SmartFrames are installed.

Begin on the left side of the wheelchair. Use a 5mm Allen wrench and a 13mm wrench to remove the three screws, two lock nuts and the tie down from the front-left rail (Figure 10).

Place the Left SmartFrame (B) so that the front hole on the bracket lines up with the front hole on the rail. Loosely insert one M8 x 16mm Low Profile Socket Cap Screw (S) into the next to last hole (Figure 11).

i Note: To aid in reinstalling the tie down, use a piece of masking tape to hold each M8 Nylon Insert Locknut (Y) in the wrench (Figure 12).

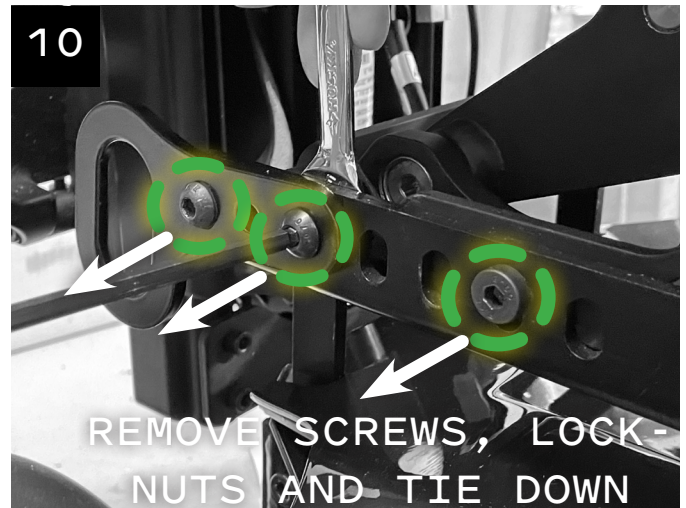

Insert an M8 x 22mm Socket Head Screw (R) through the tie down and loosely connect it to the Left SmartFrame (B), with the M8 Locknut (Y) on the back (Figure 13). Repeat with the second M8 x 22mm Socket Head Screw (R) and M8 Locknut (Y) to secure the tie down (Figure 14). Make sure the bubble is between the lines on the level taped to the Left SmartFrame (B) and tighten all three screws (Figure 15). The manufacturer recommends 25 N-m (18 ft-lb) of torque on these fasteners. Remove the bubble level once the SmartFrame is level and secure.

Repeat the process on the other side of the wheelchair to secure the Right SmartFrame (C).

i Note: If the wheelchair has headlights, reattach them now. Using the contents of the Head/Tail Light Hardware Kit (M), slide a steel washer and rubber washer onto the threaded stud. Insert the M4 x 30mm screw into the headlight and attach the headlight to the SmartFrame (Figure 16). Repeat on the other side.

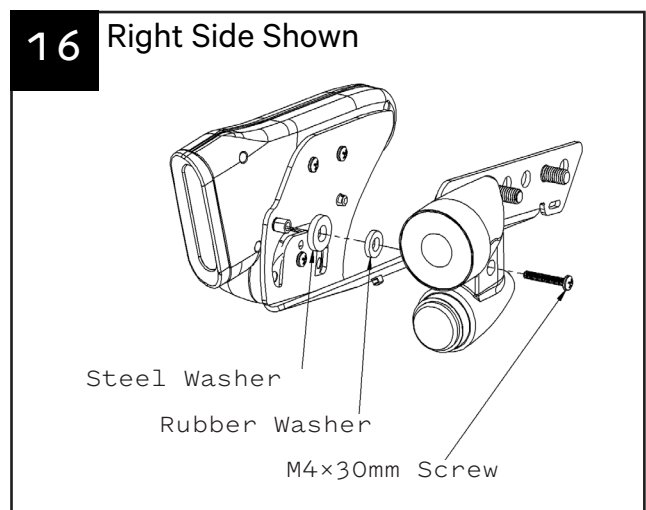

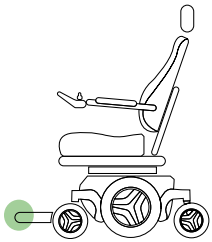

STEP 5 - ATTACH SCOUT

Tools Required

- Scout (D)
- Footplate Drill Guides (E)
- Drill
- Phillips P1 Screwdriver
- 1/4" Drill Bit (P)
- 5/16" Drill Bit (Q)
- M5 x 14mm Screw (U)
- M5 x 8mm Screws (W)
- M5 Nylon Locknut (Z)
- #10 Washer (AA)
- 8mm Socket Wrench

Choose the correct Drill Guide (E) depending on the wheelchair's footplate - Single Footplate or Dual (Individual) Footplates - and tear it out along the perforated lines.

Single Footplate:

Line up the template as shown in the image on the Drill Guide and tape it to the footplate (Figure 17A). Drill the two larger holes with the 5/16" drill bit (Q) and the smaller hole with the 1/4" drill bit (P) as marked on the template (Figure 18A). Place the Scout (D) on top of the footplate, aligning the screw holes in the bracket with the drilled holes in the footplate. Place #10 Washers (AA) on two of the M5 x 8mm Phillips Head Screws (W), raise the footplate and loosely insert the screws into the 5/16" holes from the bottom of the footplate (Figure 19A) to hold the Scout bracket in place. Insert the M5 x 14mm Screw (U) into the 1/4" hole from the top of the footplate (Figure 20A). Use an 8mm socket wrench to secure it from the bottom with the M5 Nylon Locknut (Z). Tighten all three screws.

Dual Footplates:

Line up the template as shown in the images on the Drill Guide and tape it to the footplate (Figure 17B). Note which slot on the template to line up with the footplate, depending on the footplate style. Loosely insert one M5 x 8mm Phillips Head Screw (W) through the template and into the threaded hole to help keep the template in place. Drill the two holes with the 5/16" drill bit (Q) as marked on the template (Figure 18B). Remove the M5 x 8mm screw (W) and discard the template. Place the Scout (D) on top of the footplate, aligning the screw holes in the bracket with the drilled holes in the footplate. Loosely reinsert the M5 x 8mm Screw (W) into the threaded hole (Figure 19B). Raise the footplate, place #10 Washers (AA) on the remaining two M5 x 8mm Phillips Head Screws (W) and insert them into the 5/16" holes from the bottom of the footplate (Figure 20B). Tighten all three screws.

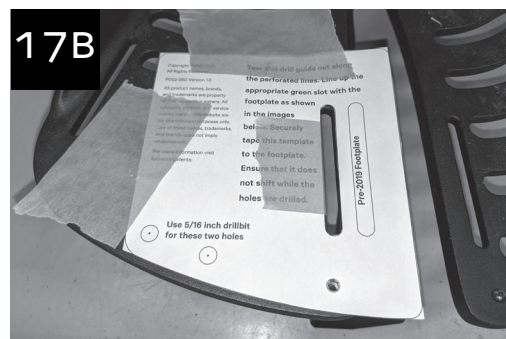
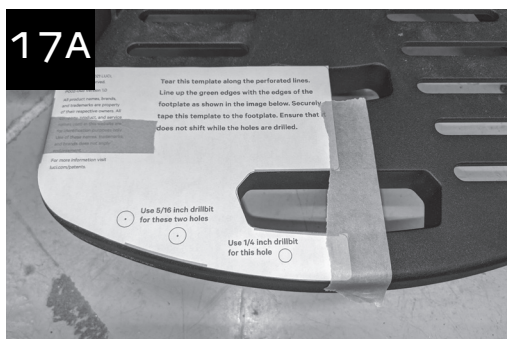

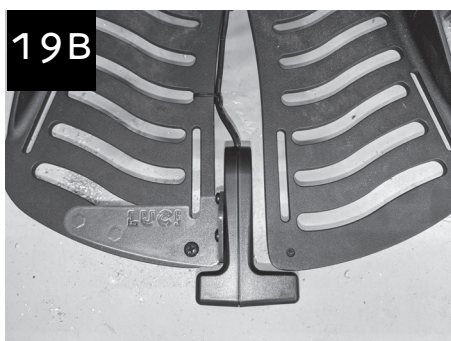
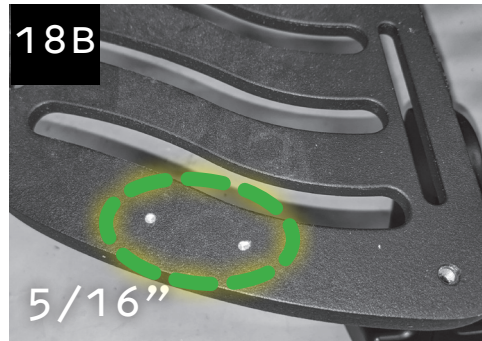
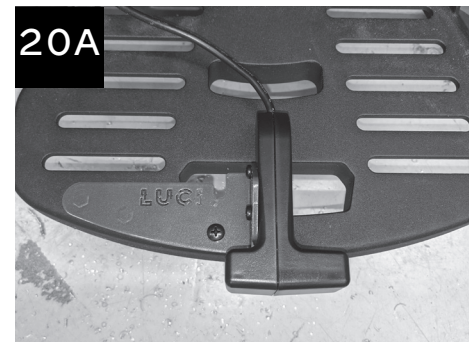

⚠ Caution: The Scout should be level for optimal performance (Figure 21A). In some cases, the footrest and Scout angle downward when the user is seated (Figure 21B). To ensure that the Scout does not see the ground as an obstacle, angle the footrest and/or Scout slightly upward (Figure 22A) so that the Scout is level when the user is seated (Figure 22B).

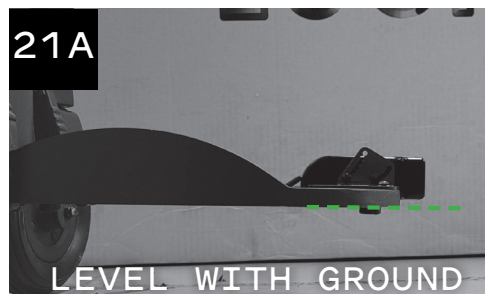

i Note: If the driver typically drives with the footplate raised, the Scout should be adjusted, following the instructions in Step 5B.

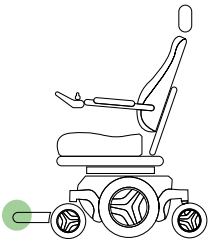

STEP 5B - ADJUSTABLE SCOUT OPTIONS

Tools Required

- Phillips P1 Screwdriver

The Scout works best when it is level with the ground or facing slightly upward. For the majority of drivers the default Scout position will work well and this step can be skipped (Figure 23). However, if the driver primarily drives with the footplate significantly raised or lowered, the Scout should be adjusted to an orientation that is level with the ground, to ensure proper functioning and obstacle detection.

The adjustable footplate bracket allows for variability in Scout orientation (Figure 24). If the driver typically drives with the footplate up, the Scout can be mounted at up to 30 degrees tilt (Figure 25).

⚠ Caution: Do not mount the Scout facing downward, as this will cause it to see the ground as an obstacle and inhibit forward motion (Figure 26). Note that the Scout should be checked with the user seated, because the footplates tend to tilt downward with weight applied.

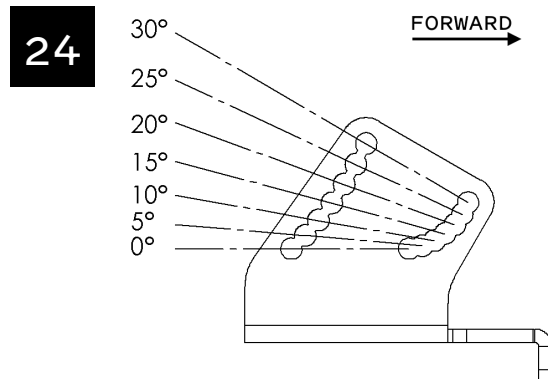

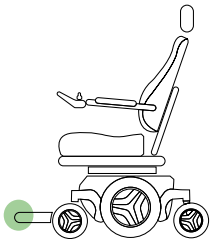

STEP 6 - ROUTE SCOUT CABLE

Tools Required

- Alcohol Wipe (N)
- Cable Clips (AC)
- Zip Ties (AB)

Route the Scout cable along the side and top of the footplate (Figure 27), using zip ties (AB) and cable clips (AC) along the way as needed. Before applying cable clips, be sure to thoroughly clean the plastic with an alcohol wipe (N). Raise the leg rest to its fullest extent and continue routing the cable along the side of the leg rest, routing toward the back of the wheelchair. Follow existing cabling and cable clips where possible (Figure 28).

⚠ Caution: Do not route the cable under the leg rest post.

ℹ Note: Use an alcohol wipe to thoroughly clean the plastic before applying cable clips. Cable clips need firm pressure to properly adhere, and may come off in the first few minutes if moved too aggressively when putting cables into them.

⚠ Caution: Ensure there is enough slack in the USB cable so that the seat and leg rest can move to their full extent, without causing tension on the cable.

⚠ Caution: All cables should be installed, bundled and routed so as to avoid damage to the cables through pinching, dragging, etc. and to avoid excess cable length that could lead to entanglement or strangulation.

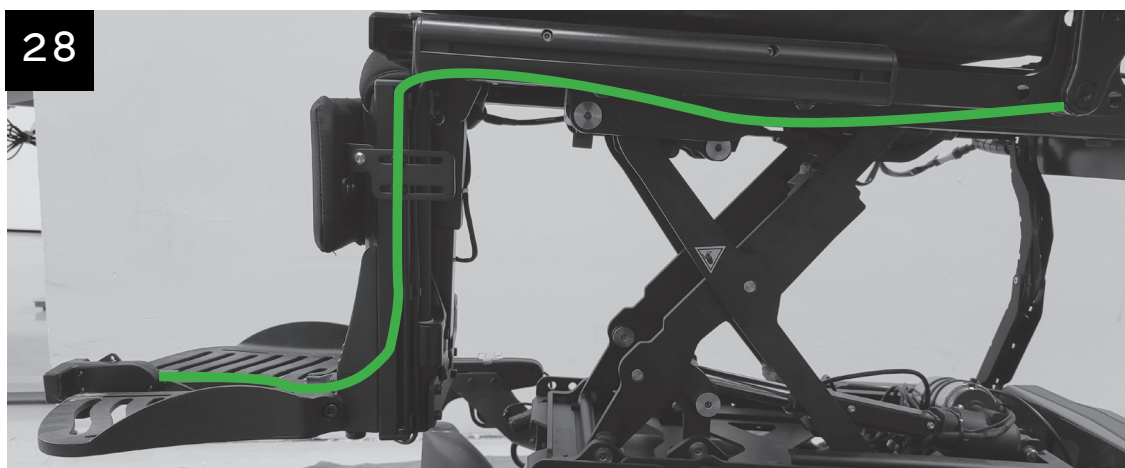
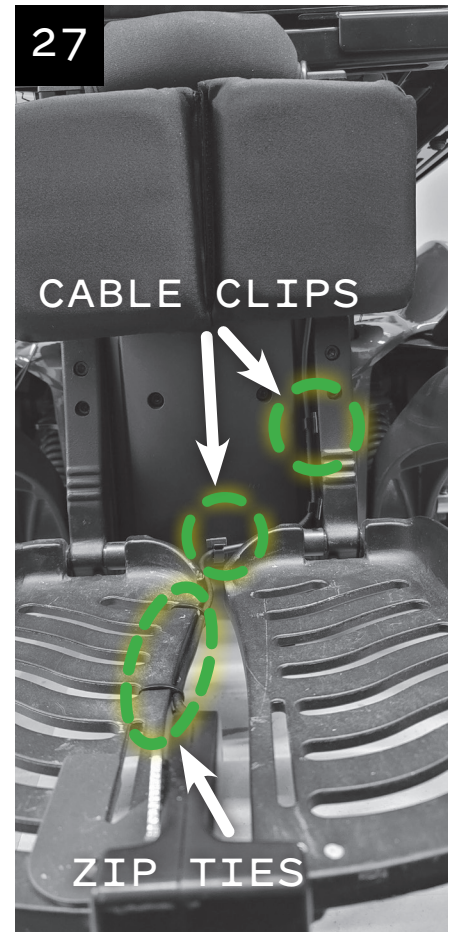

STEP 7 - INSTALL THE DASHBOARD

i Note: To install the Dashboard, you will need to select the correct Dashboard Bracket depending on the wheelchair's drive system:

- LED Joystick - LED Joystick Dashboard Bracket (H) - Step 7A
- Color Joystick - Color Joystick Dashboard Bracket (I) - Step 7B
- Standard Joystick - CJSM 1/2 Dashboard Bracket (K) - Step 7C
- Omni Alternative Drive - Omni Dashboard Bracket (L) - Step 7D

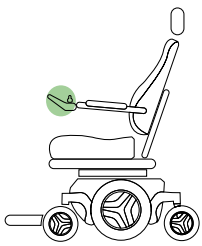

STEP 7A - LED JOYSTICK

- Tools Required
- Dashboard (F)
 - Dashboard Reference Card (G)
 - LED Joystick Dashboard Bracket (H)
 - 3mm Allen Wrench
 - 5mm Allen Wrench
 - Phillips P1 Screwdriver
 - M5x16mm Hex Screws (T)
 - 4-40 x 3/16 Phillips Screws (X)

Remove the joystick module from the armrest of the wheelchair by loosening the M6 screw using a 5mm Allen wrench (Figure 29). Remove the two screws on the bottom of the joystick on either side of the adjustment rod, using a 3mm Allen wrench (Figure 30). Choose the correct (left or right) Dashboard Reference Card (G). Use four 4-40 x 3/16 inch screws (X) to attach the LED Joystick Dashboard Bracket (H) to the back of the Dashboard (F), with the Dashboard Reference Card (G) behind the bracket (Figure 31). Route the Dashboard cable

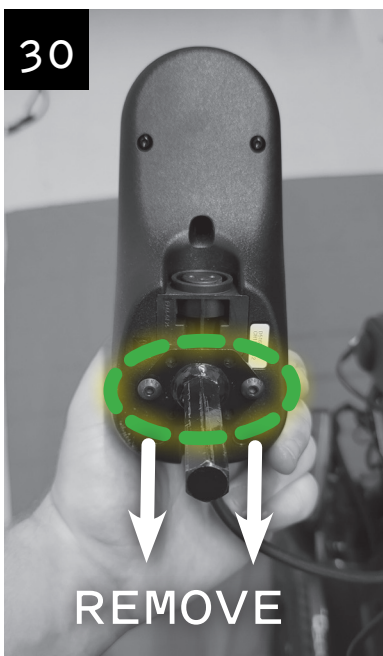
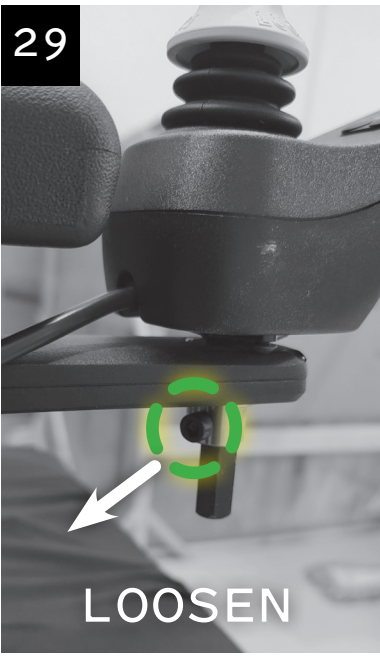

along the lower inside bend of bracket and place the joystick module inside the Bracket. Insert two M5 x 16mm hex head screws (T), tightening them with a 3mm Allen wrench (Figure 32). Reattach the entire joystick module to the wheelchair and tighten the original M6 screw (Figure 33).

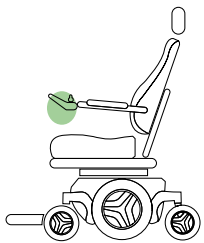
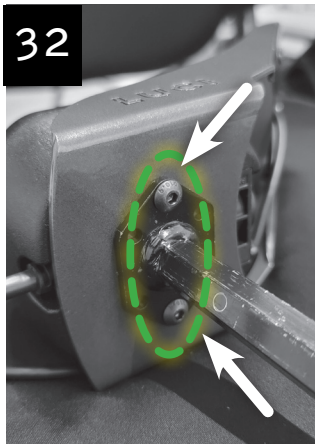
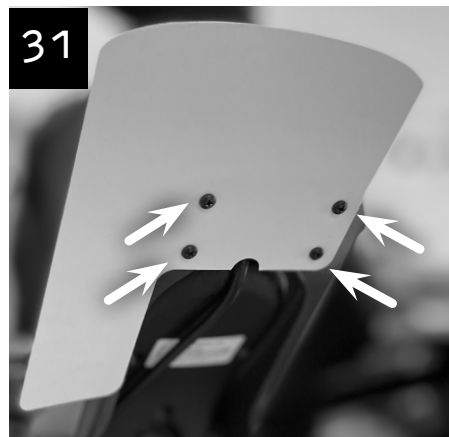

STEP 7B - COLOR JOYSTICK

Tools Required

- Dashboard (F)
- Dashboard Reference Card (G)
- Color Joystick
- Dashboard Bracket (I)
- Color Joystick Spacer (J)
- 3mm Allen Wrench
- 5mm Allen Wrench
- Phillips P1 Screwdriver
- M5x16mm Hex Screws (T)
- 4-40 x 3/16 Phillips Screws (X)

Remove the joystick module from the armrest of the wheelchair by loosening the M6 screw using a 5mm Allen wrench (Figure 34). Remove the two screws on the bottom of the joystick on either side of the adjustment rod, using a 3mm Allen wrench (Figure 35). Feed the joystick cable through

the split in the Color Joystick Bracket (I) (Figure 36). Choose the correct (left or right) Dashboard Reference Card (G). Use four 4-40 x 3/16 inch screws (X) to attach the Color Joystick Dashboard Bracket (I) to the back of the Dashboard (F), with the Dashboard Reference Card (G) behind the bracket (Figure 37). Route the Dashboard cable along the lower inside bend of bracket and place the joystick module inside the bracket. Turn the joystick module upside down, and slide the Color Joystick Spacer (J) in between the joystick module and the bracket (Figure 38). Insert two M5 x 16mm hex head screws (T), tightening them with a 3mm Allen wrench (Figure 39). Reattach the entire joystick module to the wheelchair and tighten the original M6 screw (Figure 40).

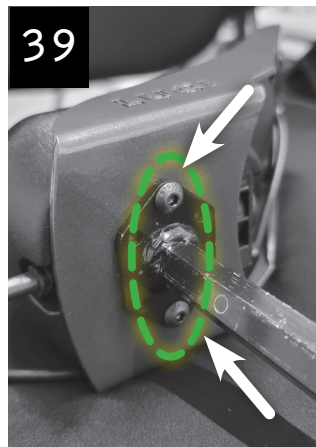
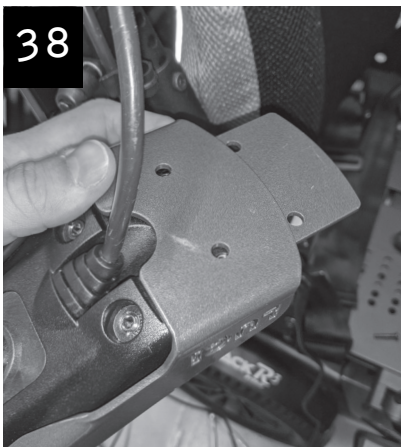
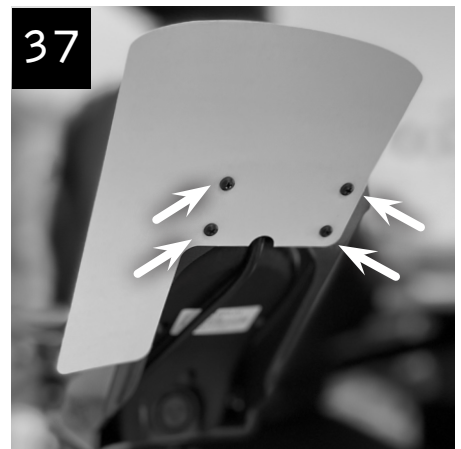
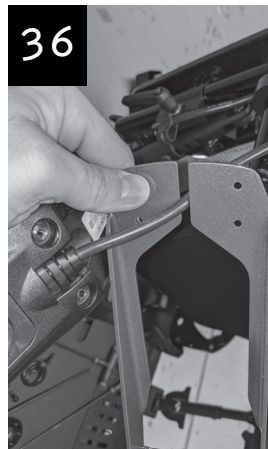
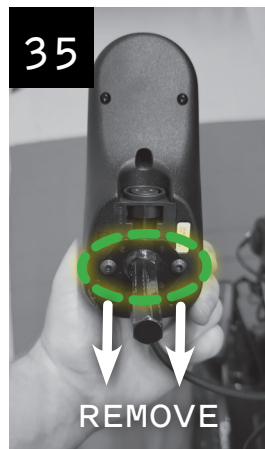

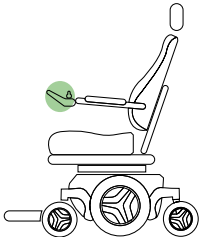

STEP 7C - CJSM 1/2 JOYSTICK

Tools Required

- Dashboard (F)
- Dashboard Reference Card (G)
- CJSM 1/2 Joystick
- Dashboard Bracket (K)
- 3mm Allen Wrench
- 5mm Allen Wrench
- Phillips P1 Screwdriver
- 4-40 x 3/16 Phillips Screws (X)
- Zip Tie (AB)

Choose the correct (left or right) Dashboard Reference Card (G). Use four 4-40 x 3/16 inch screws (X) to attach the bracket to the back of the Dashboard (F), sandwiching the Dashboard Reference Card (G) between them and ensuring the cable is routed correctly (Figure 41A or 41B). Note that for newer wheelchairs, the joystick module is taller, so the Dashboard should only be attached to the top two holes on the bracket; insert screws into the top two holes on the Dashboard (F) to ensure the unit stays sealed (Figure 41B). Remove the joystick module from the armrest of the wheelchair by loosening the M6 screw using a 5mm Allen wrench. Use a 3mm Allen wrench to remove the metal bracket from the joystick module. Insert the Dashboard bracket between the armrest and the joystick module and reinsert the screws (Figure 42). Route and zip tie the cable as shown (Figure 42). Reattach the joystick module and tighten the original M6 screw.

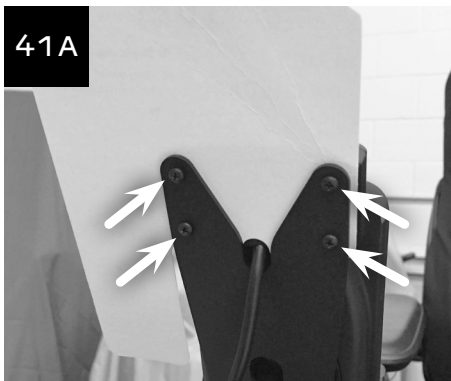

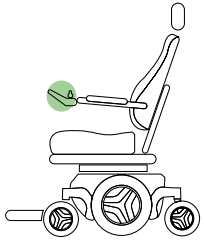

STEP 7D - OMNI ALTERNATIVE DRIVE

Tools Required

- Dashboard (F)
- Dashboard Reference Card (G)
- Omni Dashboard Bracket (L)
- 3mm Allen Wrench
- Phillips P1 Screwdriver
- M5 x 8mm Hex Screw (V)
- 4-40 x 3/16 Phillips Screws (X)

Choose the correct (left or right) Dashboard Reference Card (G). Use four 4-40 x 3/16 inch screws (X) to attach the bracket to the back of the Dashboard (F), sandwiching the Dashboard Reference Card (G) between them and ensuring the cable is routed correctly (Figure 43). Use a 3mm Allen wrench to remove the Omni module. Insert the Dashboard bracket between the armrest and the Omni module and attach using two M5 x 8mm hex head screws (V) (Figure 44).



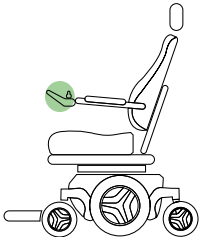

STEP 8 - ROUTE THE DASHBOARD CABLE

Tools Required

- Zip Ties (AB)

Regardless of the type of Dashboard Bracket that was used, route the Dashboard cable toward the back of the wheelchair, following existing cabling and using zip ties (AB) as needed (Figure 45).

i Note: For alternative drive wheelchairs, the Dashboard (F) includes an auxiliary jack. Any momentary switch plugged into the jack can be used as the override button. If not used, be sure to keep the dust plug in the jack.

▲ Caution: All cables should be installed, bundled and routed so as to avoid damage to the cables through pinching, dragging, etc. and to avoid excess cable length that could lead to entanglement or strangulation.

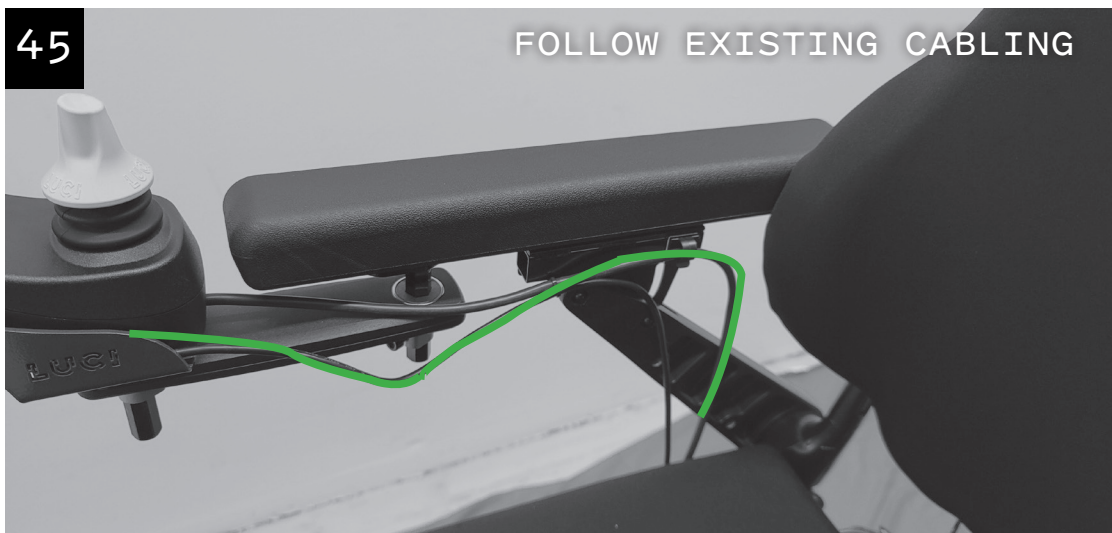

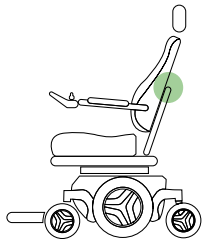

STEP 9 - ATTACH LUCILINK HUB

Tools Required

- Alcohol Wipe (N)
- Zip Ties (AB)
- LuciLink Hub (O)
- Phillips P1 Screwdriver

Use an alcohol wipe (N) to clean a flat area on the wheelchair seat back. Remove the Velcro backing from the LuciLink Hub (O) back cover and affix it to the cleaned area, so that the key is oriented as shown and the cable opening is at the bottom (Figure 46). Clip existing zip ties along the drag chain one at a time and route the Rear SmartFrame USB cable along existing cabling and through the drag chain, zip tying it in place (Figure 47). Use long zip ties (AB) to secure cables in the drag chain.

i Note: The LuciLink Hub may be placed anywhere on the seat back, as long as it does not limit the range of motion of the seat, armrests, etc.

i Note: Leave about 4-6 inches of slack in the USB cable before inserting it into the drag chain, so that SmartFrame can be rotated out of the way to allow for battery changes.

Use a Phillips P1 screwdriver to open the LuciLink Hub. Plug the Scout and Dashboard USB cables into the LuciLink Hub and connect the SmartFrame USB cable to the LuciLink Hub. Place the cables so that the LuciLink Hub can be closed (Figure 48). Close the LuciLink Hub, reinsert and tighten the three screws (Figure 49).

i Note: It may be easier to place the cables and close the LuciLink Hub by removing the back from the Velcro and holding the LuciLink Hub horizontally.

▲ Caution: All cables should be installed, bundled and routed so as to avoid damage to the cables through pinching, dragging, etc. and to avoid excess cable length that could lead to entanglement or strangulation.

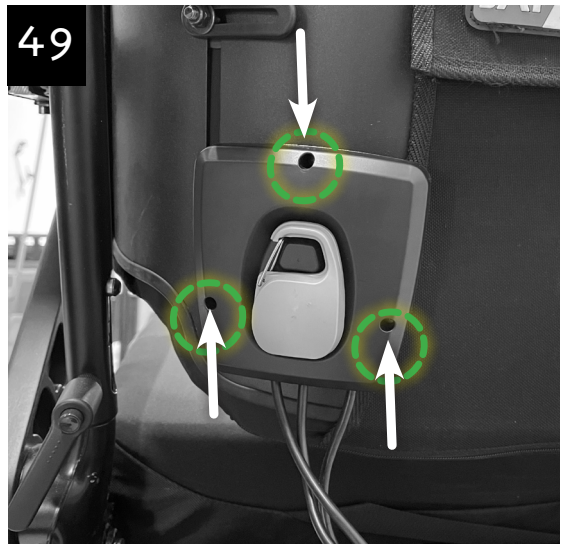
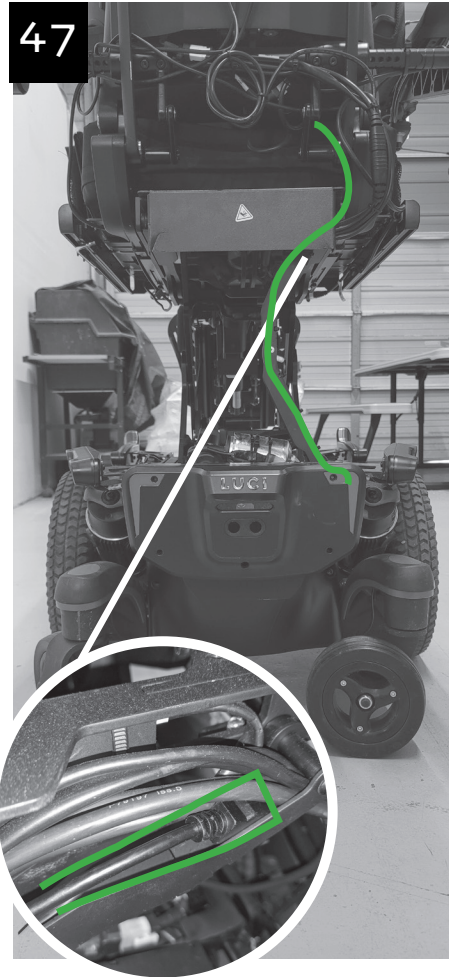

ONCE LUCI IS INSTALLED:

- Power on the wheelchair and ensure that the seat, armrests, and footrest are able to move to their full extent without pinching or pulling any cables, or compressing any parts of LUCI.
- Ensure that leg pads and accessories, such as lateral thigh supports, do not contact or block the front camera pods and/or headlights at the lowest seat elevation.
- Confirm the Dashboard Reference Card is attached to the LUCI Dashboard.
- Check that there are no loose, pinched or dragging cables.
- Confirm the Sensor Status light on the Dashboard is orange (demo mode).
- Press the LUCI button and make sure the LUCI button lights up blue, the chair can move in each direction when clear, and the chair stops in a blocked direction of travel.

Before releasing the wheelchair to the user, the system will need to be configured. With the user in the wheelchair, follow the instructions in the LUCI Quick Setup Guide.

CONGRATULATIONS,
you have installed

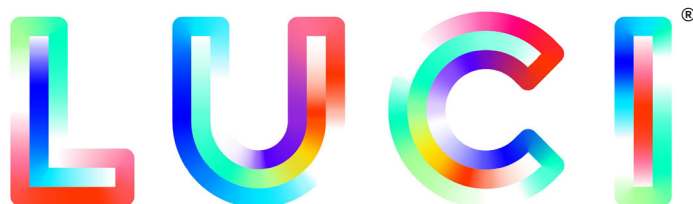
The logo for LUCI, featuring the letters L, U, C, and I in a stylized, colorful font. Each letter is composed of multiple overlapping, semi-transparent shapes in various colors (red, orange, yellow, green, blue, purple) that create a vibrant, multi-colored effect. A registered trademark symbol (®) is located to the upper right of the letter 'I'.

Copyright © 2021 LUCI, All Rights Reserved.

All product names, brands, and trademarks are property of their respective owners. All company, product, and service names used are for identification purposes only. Use of these names, trademarks, and brands does not imply endorsement.

For more information on our patents, please visit luci.com/patents

REPLACING WHEELCHAIR BATTERIES WITH LUCI INSTALLED

If you need to replace the batteries on a Quickie Q300 M that has LUCI installed, follow these steps:

1. Remove the thumbscrews attaching the seating assembly to the front seat posts and tilt the seating assembly back to gain access to the base of the chair

⚠ Caution: Use the kickstand and do not go past the kickstand travel to avoid damaging the Rear SmartFrame.

2. Swap the batteries as you normally would.

3. Close the seating assembly and reinsert the thumbscrews. Ensure all cables remain neatly routed to avoid pinching or dragging.



LUCI[®]

LUCI.COM

P002-044 v 3.0